



PixelArch Ltd.

Canada main office:
3313 Plateau Blvd.
Coquitlam BC V3E 3B8
+1 604 243 3666

US Office:
1442 N. Dale Ave.
Anaheim, CA 92801
+1 310 734 8517

Toll free: 1 844 729 0009
Email: info@pixelarchpro.com

GENERAL NOTE

All measurements to be verified on site by contractor.

REVISED:
January 10, 2017

DATE:
04.12.2016

COPYRIGHT

THIS DRAWING IS AN INSTRUMENT OF SERVICE AND AS SUCH, REMAINS THE PROPERTY OF PIXELARCH LTD. PERMISSION FOR USE OR REPRODUCTION IS LIMITED AND CAN BE EXTENDED ONLY BY WRITTEN PERMISSION WITH OWNER, PIXELARCH LTD.

No.	Revision/Issue	Date

Firm Name and Address

Darren Asad Architect
darrenasad@mail.com

Project Name and Address

901 N BEDFORD DR. BEVERLY HILLS, CA

DRAWING: FIRST FLOOR LIGHTING	Sheet 8 OF 8
Date January 10, 2017	A100
Scale NTS	

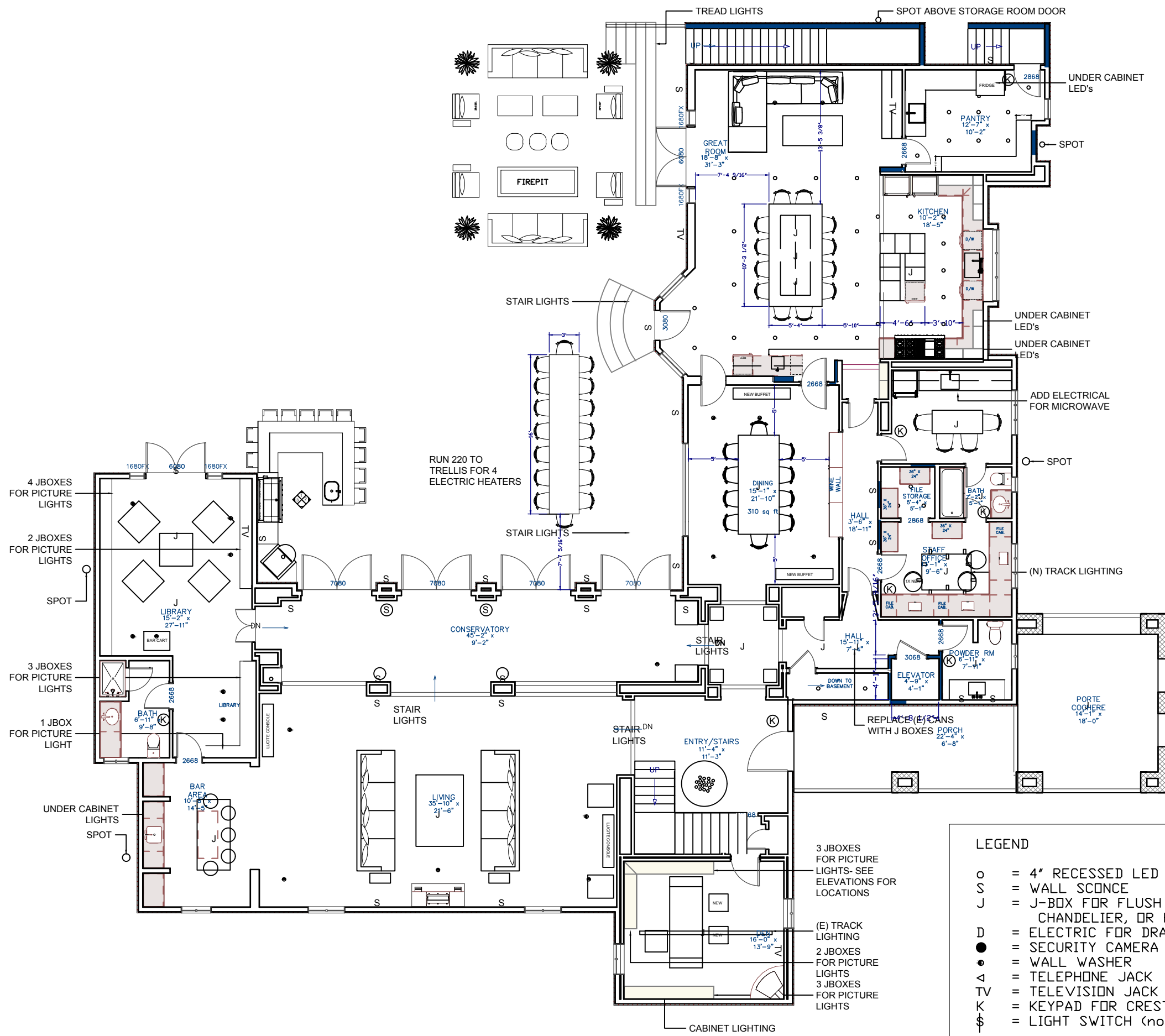

LEGEND

- = 4" RECESSED LED
- S = WALL SCNCE
- J = J-BOX FOR FLUSH MOUNT, CHANDELIER, OR PENDANT
- D = ELECTRIC FOR DRAPES
- = SECURITY CAMERA
- ◐ = WALL WASHER
- △ = TELEPHONE JACK
- TV = TELEVISION JACK
- K = KEYPAD FOR CRESTRON
- ⋈ = LIGHT SWITCH (non-crestron)

(E) TRACK LIGHTING

3 JBOXES FOR PICTURE LIGHTS- SEE ELEVATIONS FOR LOCATIONS

2 JBOXES FOR PICTURE LIGHTS

3 JBOXES FOR PICTURE LIGHTS

CABINET LIGHTING



PixelArch Ltd.

Canada main office:
3313 Plateau Blvd.
Coquitlam BC V3E 3B8
+1 604 243 3666

US Office:
1442 N. Dale Ave.
Anaheim, CA 92801
+1 310 734 8517
Toll free: 1 844 729 0009
Email: info@pixelarchpro.com

GENERAL NOTE

All measurements to be verified on site by contractor.

REVISED:
January 10, 2017

DATE:
04.21.2016

COPYRIGHT

THIS DRAWING IS AN INSTRUMENT OF SERVICE AND AS SUCH, REMAINS THE PROPERTY OF PIXELARCH LTD. PERMISSION FOR USE OR REPRODUCTION IS LIMITED AND CAN BE EXTENDED ONLY BY WRITTEN PERMISSION WITH OWNER, PIXELARCH LTD.

No.	Revision/Issue	Date

Firm Name and Address

Darren Asad Architect
darrenasad@mail.com

Project Name and Address

901 N BEDFORD DR. BEVERLY HILLS, CA

DRAWING: GH UPPER LIGHTING PLAN	Sheet 0 OF 0
Date January 10, 2017	A100
Scale 1/8" = 1' - 00"	

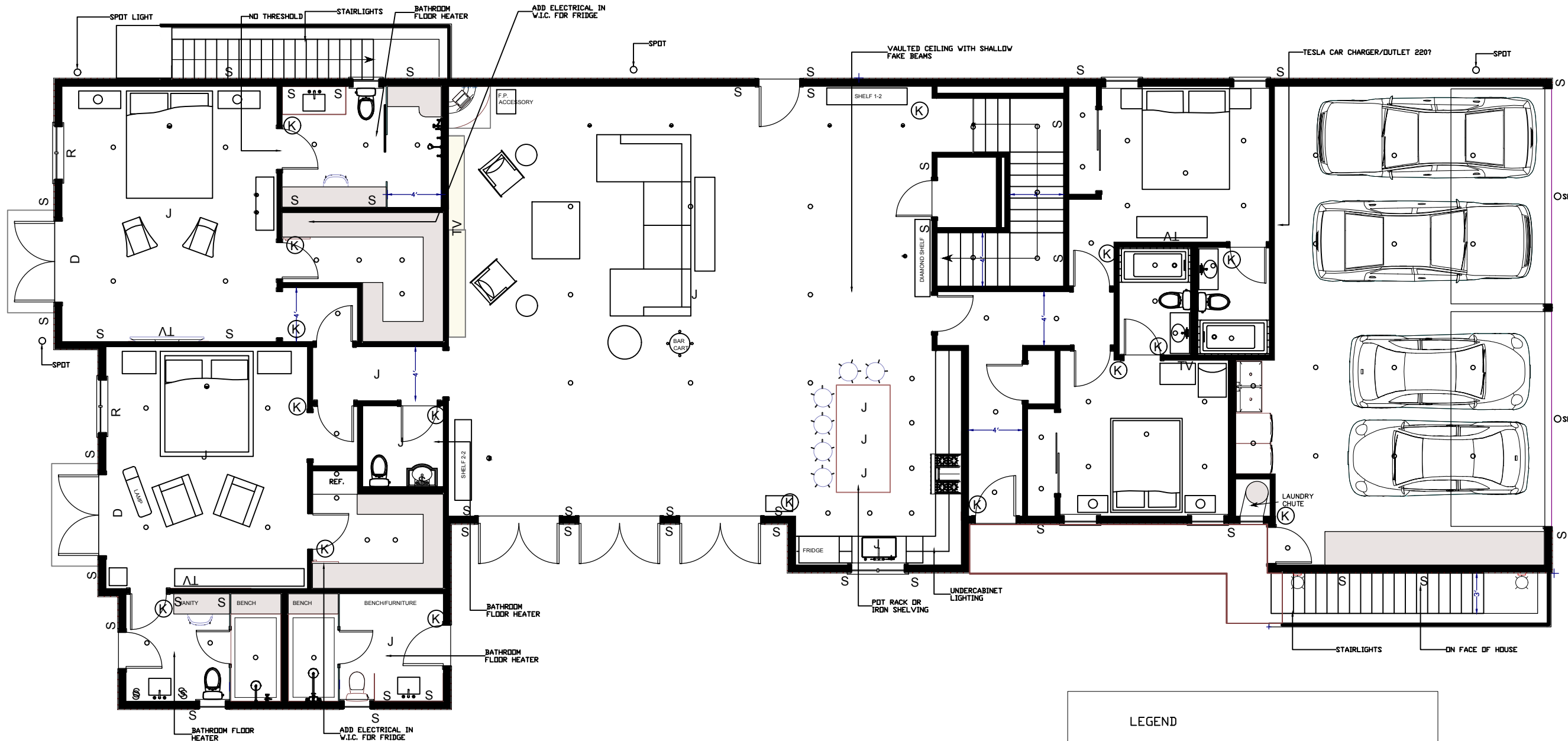

- LEGEND**
- o = 4" RECESSED LED
 - S = WALL SCONCE
 - J = J-BOX FOR FLUSH MOUNT, CHANDELIER, OR PENDANT
 - D = ELECTRIC FOR DRAPES
 - R = ELECTRIC FOR ROMAN SHADES
 - = SECURITY CAMERA
 - = WALL WASHER
 - ◁ = TELEPHONE JACK
 - TV = TELEVISION JACK
 - K = KEYPAD FOR CRESTRON
 - § = LIGHT SWITCH (non-crestron)



PixelArch Ltd.

Canada main office:
3313 Plateau Blvd.
Coquitlam BC V3E 3B8
+1 604 243 3666

US Office:
1442 N. Dale Ave.
Anaheim, CA 92801
+1 310 734 8517

Toll free: 1 844 729 0009
Email: info@pixelarchpro.com

GENERAL NOTE

All measurements to be verified on site by contractor.

REVISED:
January 10, 2017

DATE:
04.12.2016

COPYRIGHT

THIS DRAWING IS AN INSTRUMENT OF SERVICE AND AS SUCH, REMAINS THE PROPERTY OF PIXELARCH LTD. PERMISSION FOR USE OR REPRODUCTION IS LIMITED AND CAN BE EXTENDED ONLY BY WRITTEN PERMISSION WITH OWNER, PIXELARCH LTD.

No.	Revision/Issue	Date

Firm Name and Address

Darren Asad Architect
darrenasad@mail.com

Project Name and Address

901 N BEDFORD DR. BEVERLY HILLS, CA

DRAWING: FLOOR PLAN	Sheet
Date January 10, 2017	o OF o
Scale NTS	A100

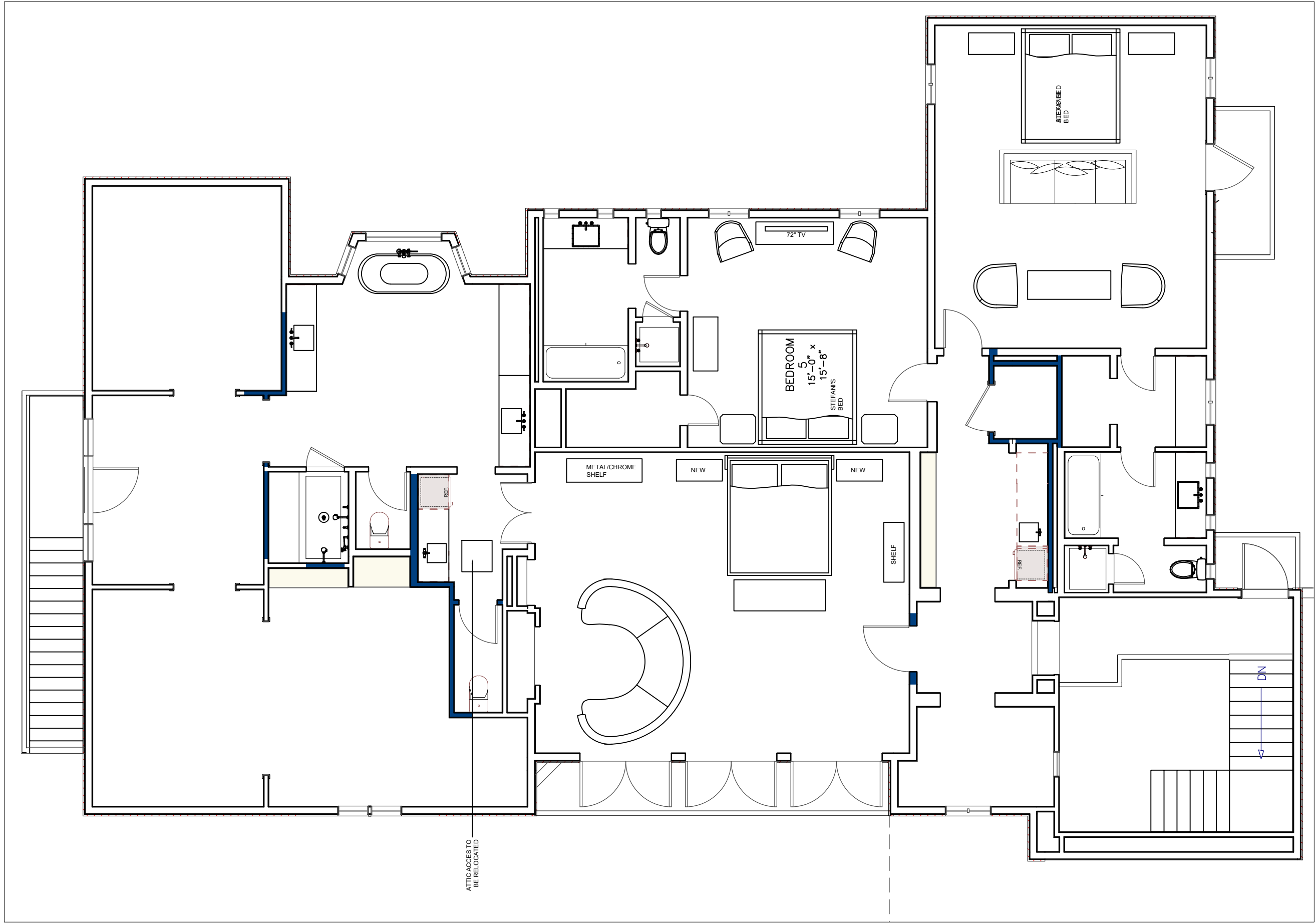

ATTIC ACCESS TO BE RELOCATED



PixelArch Ltd.

Canada main office:
3313 Plateau Blvd.
Coquitlam BC V3E 3B8
+1 604 243 3666

US Office:
1442 N. Dale Ave.
Anaheim, CA 92801
+1 310 734 8517

Toll free: 1 844 729 0009
Email: info@pixelarchpro.com

GENERAL NOTE

All measurements to be verified on site by contractor.

REVISED:
January 10, 2017

DATE:
07.06.2016

COPYRIGHT

THIS DRAWING IS AN INSTRUMENT OF SERVICE AND AS SUCH, REMAINS THE PROPERTY OF PIXELARCH LTD. PERMISSION FOR USE OR REPRODUCTION IS LIMITED AND CAN BE EXTENDED ONLY BY WRITTEN PERMISSION WITH OWNER, PIXELARCH LTD.

No.	Revision/Issue	Date

Firm Name and Address

Darren Asad Architect
darrenasad@mail.com

Project Name and Address

901 N BEDFORD DR. BEVERLY HILLS, CA

DRAWING: MASTER BAR TILE	Sheet
Date: January 10, 2017	o OF o
Scale: AS NOTED	A100

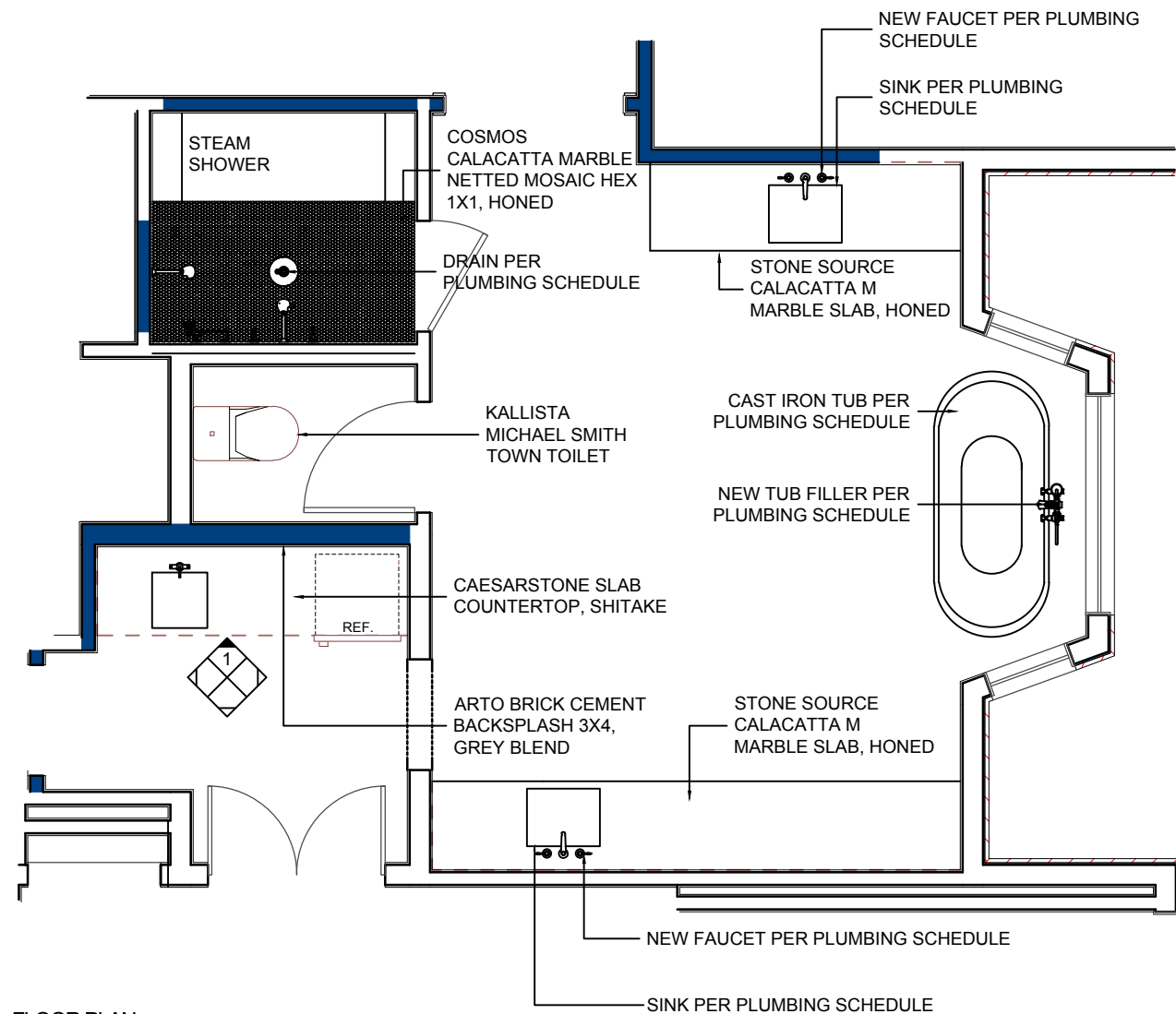

FLOOR PLAN
SCALE: 1/4" = 1'-0"

ELEVATION 1
SCALE: 3/8" = 1'-0"

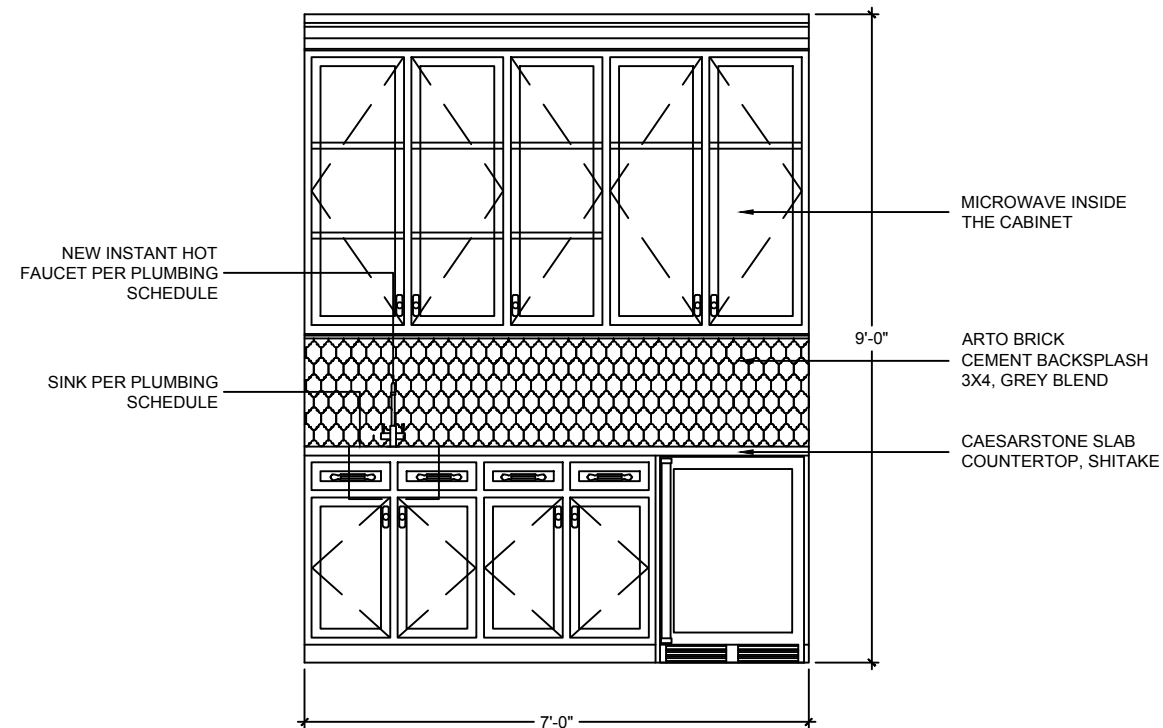

****NOTE:**
CABINETRY TO BE PAINT
FINISH

COUNTER TO BE SLAB

EXTERIOR DECORATIVE
HINGES

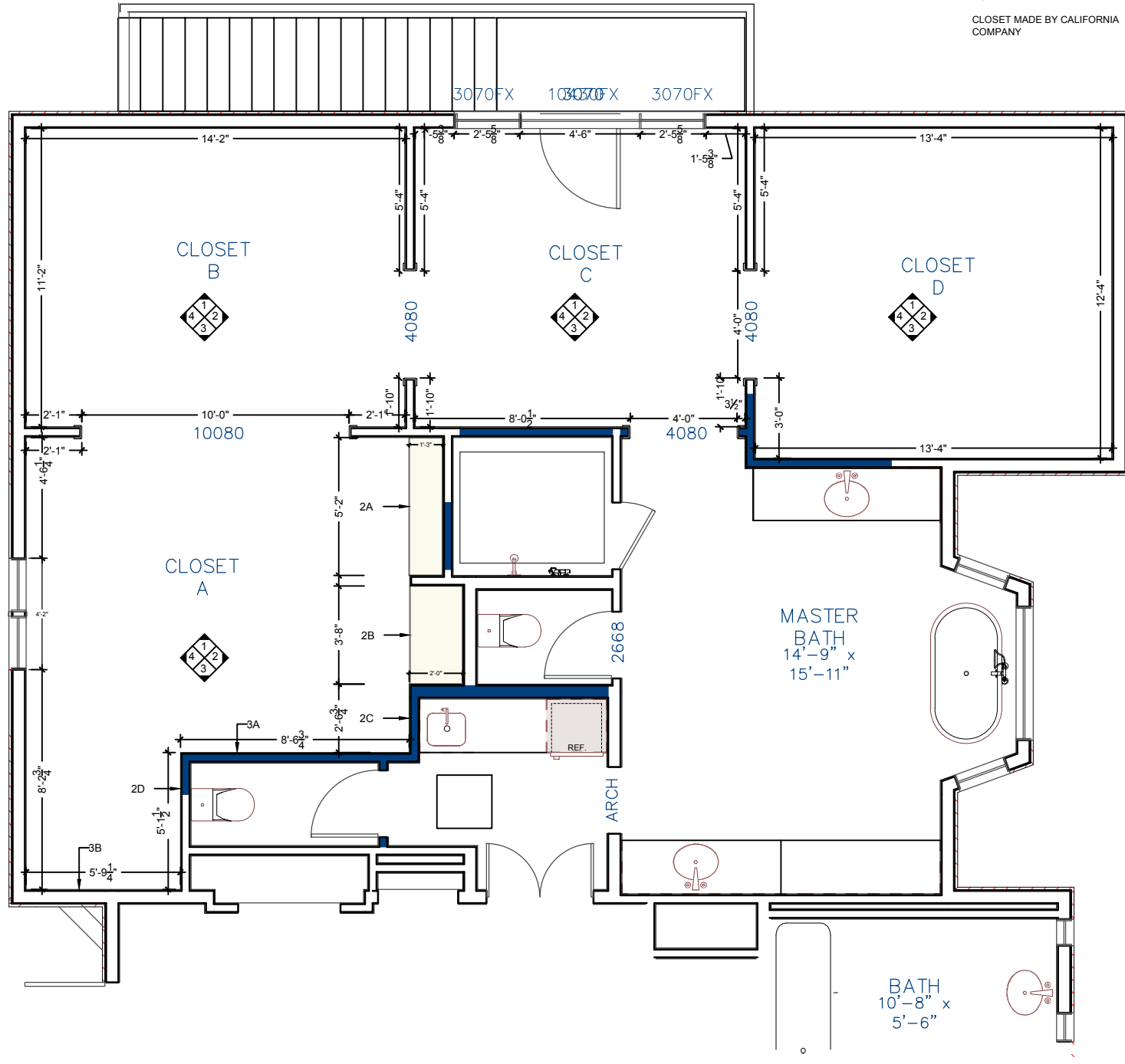

NOTE:
CLOSET MADE BY CALIFORNIA COMPANY



PixelArch Ltd.

Canada main office:
3315 Plateau Blvd.
Coquitlam BC V3E 3B8
+1 604 243 3666

US Office:
1442 N. Dale Ave.
Anaheim, CA 92801
+1 310 734 8517

Toll free: 1 844 729 0009
Email: info@pixelarchpro.com

GENERAL NOTE

All measurements to be verified on site by contractor.

REVISED:
January 10, 2017

DATE:
06.29.2016

COPYRIGHT

THIS DRAWING IS AN INSTRUMENT OF SERVICE AND AS SUCH, REMAINS THE PROPERTY OF PIXELARCH LTD. PERMISSION FOR USE OR REPRODUCTION IS LIMITED AND CAN BE EXTENDED ONLY BY WRITTEN PERMISSION WITH OWNER, PIXELARCH LTD.

No.	Revision/Issue

Plan Name and Address

Darren Asad Architect
darrenasad@mail.com

Project Name and Address

901 N BEDFORD DR. BEVERLY HILLS, CA

DATE	Sheet
MASTER CLOSET	0 OF 0
Date	January 10, 2017
Scale	NOT TO SCALE

A100



PixelArch Ltd.

Canada main office:
3313 Plateau Blvd.
Coquitlam BC V3E 3B8
+1 604 243 3666

US Office:
1442 N. Dale Ave.
Anaheim, CA 92801
+1 310 734 8517

Toll free: 1 844 729 0009
Email: info@pixelarchpro.com

GENERAL NOTE

All measurements to be verified on site by contractor.

REVISED:
January 10, 2017

DATE:
04.21.2016

COPYRIGHT

THIS DRAWING IS AN INSTRUMENT OF SERVICE AND AS SUCH, REMAINS THE PROPERTY OF PIXELARCH LTD. PERMISSION FOR USE OR REPRODUCTION IS LIMITED AND CAN BE EXTENDED ONLY BY WRITTEN PERMISSION WITH OWNER, PIXELARCH LTD.

No.	Revision/Issue	Date

Firm Name and Address

Darren Asad Architect
darrenasad@mail.com

Project Name and Address

901 N BEDFORD DR. BEVERLY HILLS, CA

DRAWING:
GH LOWER LOW VOLTAGE PLAN
Date:
January 10, 2017
Scale:
1/8" = 1' - 00"

Sheet
0 OF 0
A100

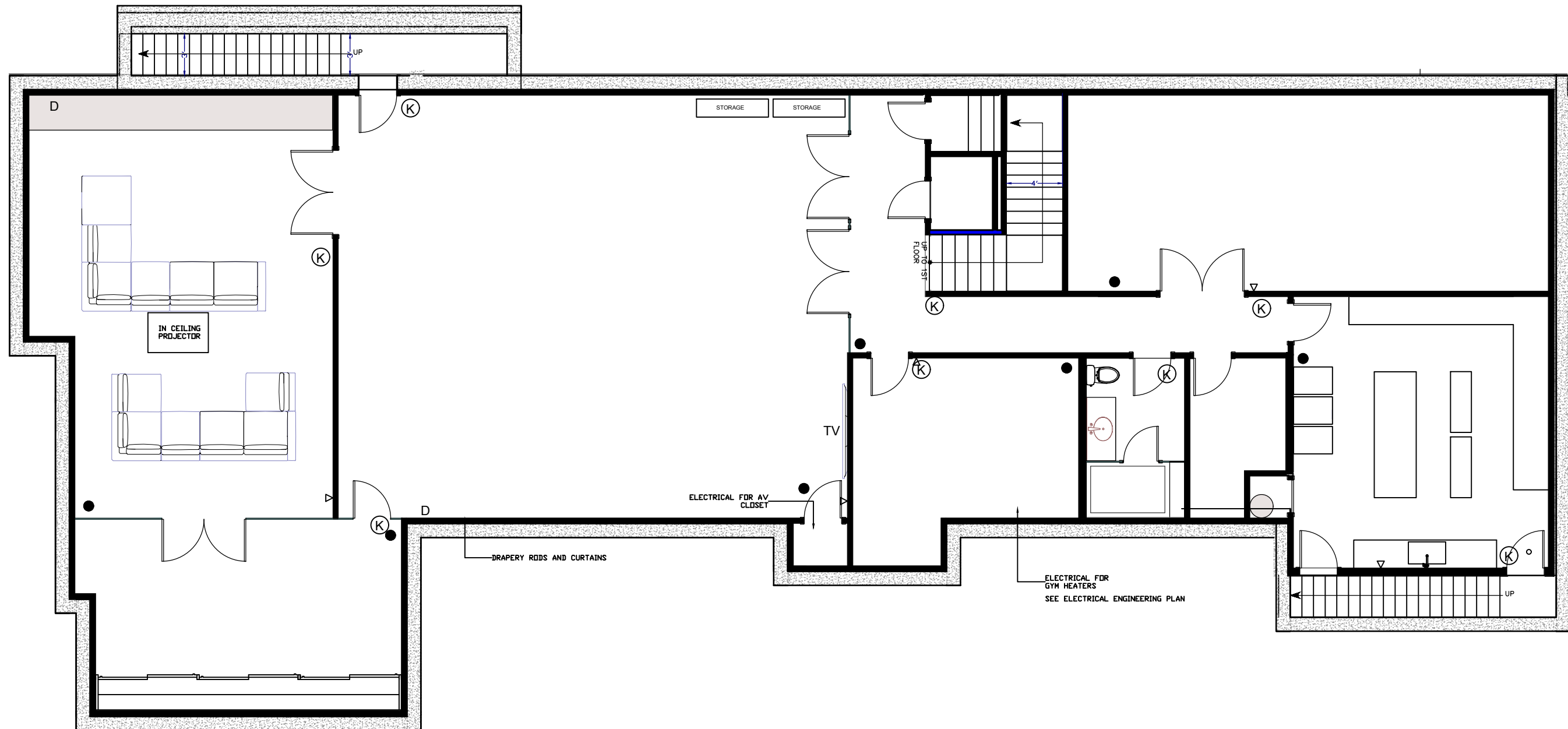



PixelArch Ltd.

Canada main office:
3313 Plateau Blvd.
Coquitlam BC V3E 3B8
+1 604 243 3666

US Office:
1442 N. Dale Ave.
Anaheim, CA 92801
+1 310 734 8517

Toll free: 1 844 729 0009
Email: info@pixelarchpro.com

GENERAL NOTE

All measurements to be verified on site by contractor.

REVISED:
January 10, 2017

DATE:
06.015.2016

COPYRIGHT

THIS DRAWING IS AN INSTRUMENT OF SERVICE AND AS SUCH, REMAINS THE PROPERTY OF PIXELARCH LTD. PERMISSION FOR USE OR REPRODUCTION IS LIMITED AND CAN BE EXTENDED ONLY BY WRITTEN PERMISSION WITH OWNER, PIXELARCH LTD.

No.	Revision/Issue	Date

Firm Name and Address

Darren Asad Architect
darrenasad@mail.com

Project Name and Address

901 N BEDFORD DR. BEVERLY HILLS, CA

DRAWING:
EXTERIOR WINDOWS
Date
January 10, 2017
Scale
AS NOTED

Sheet
0 OF 0
A100

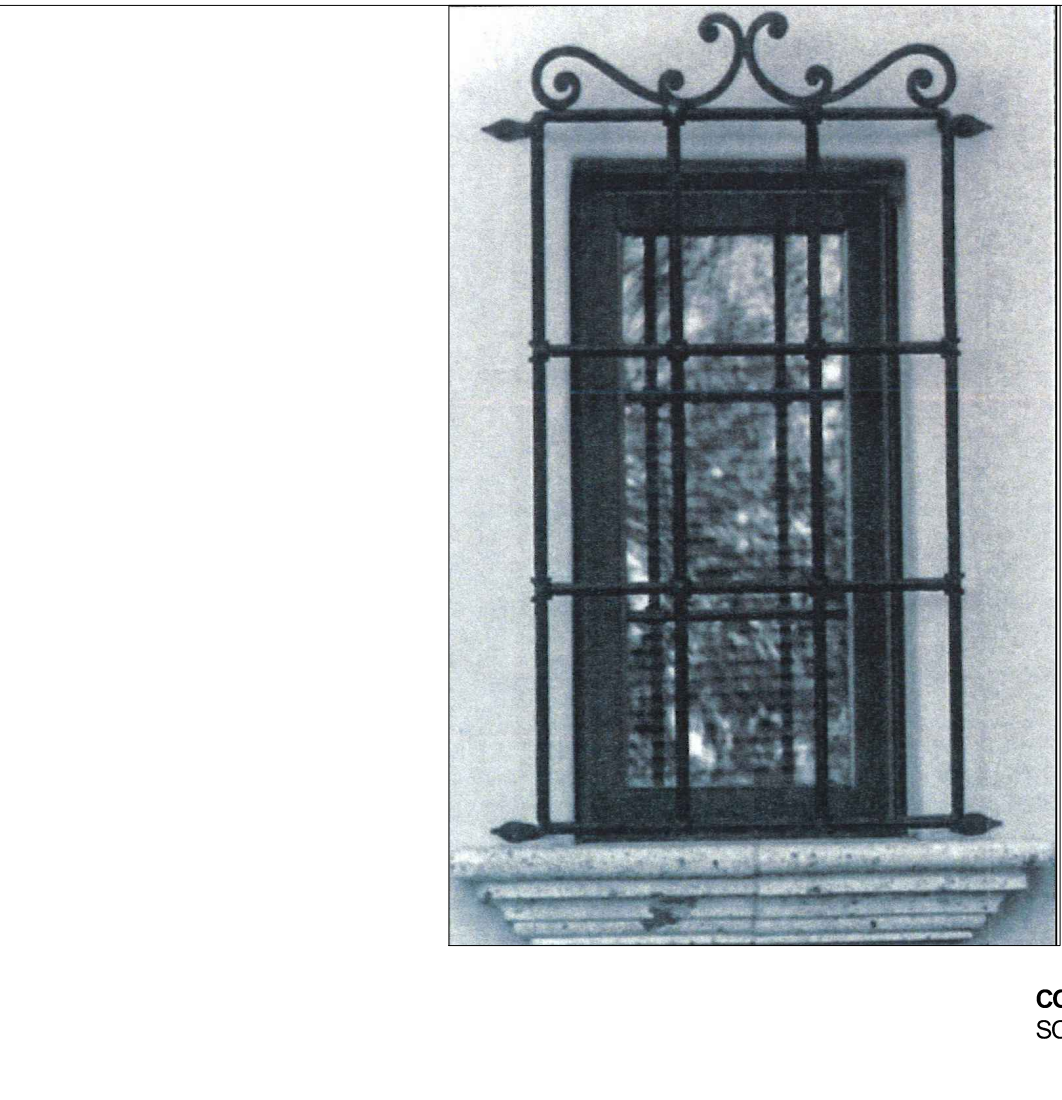
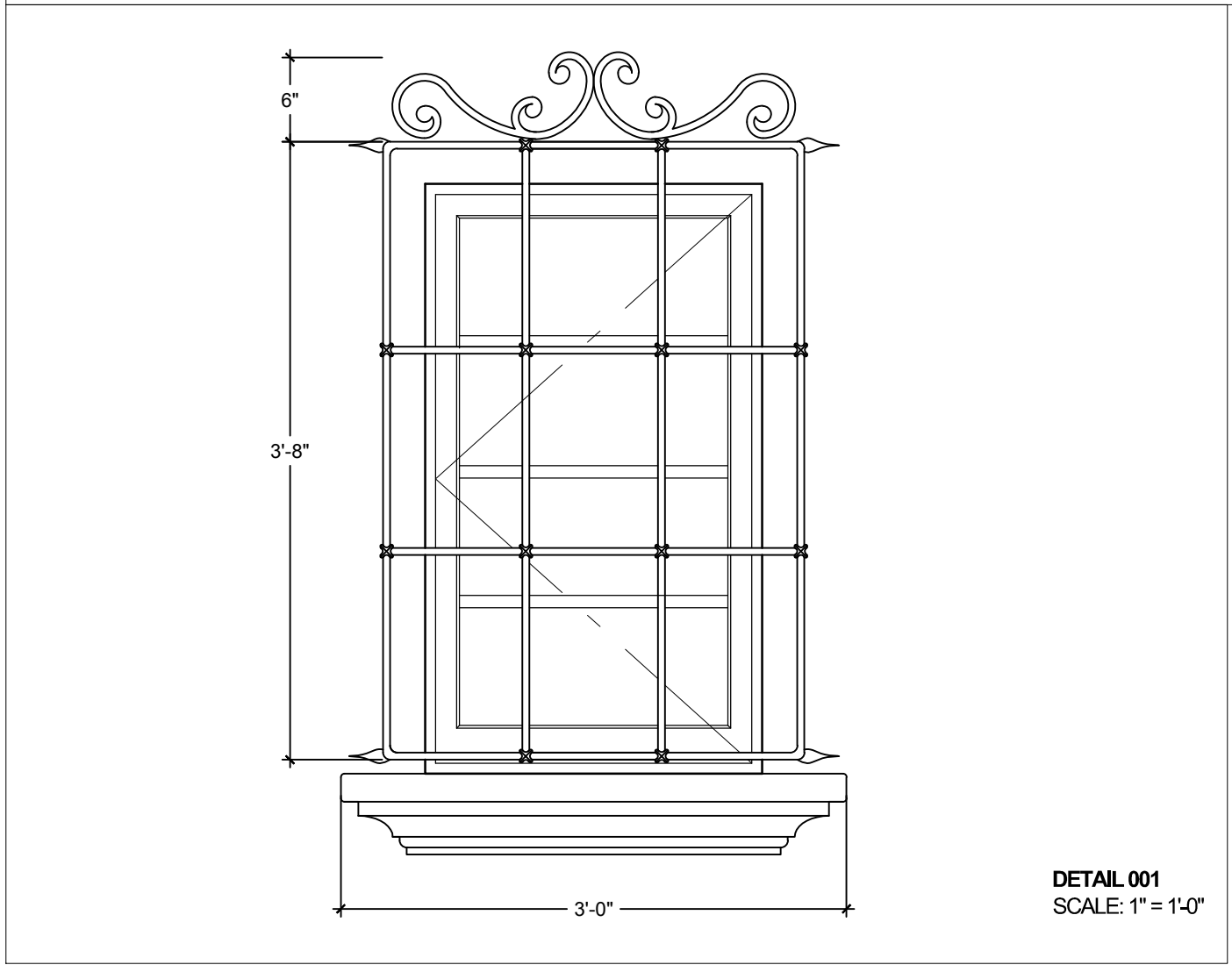
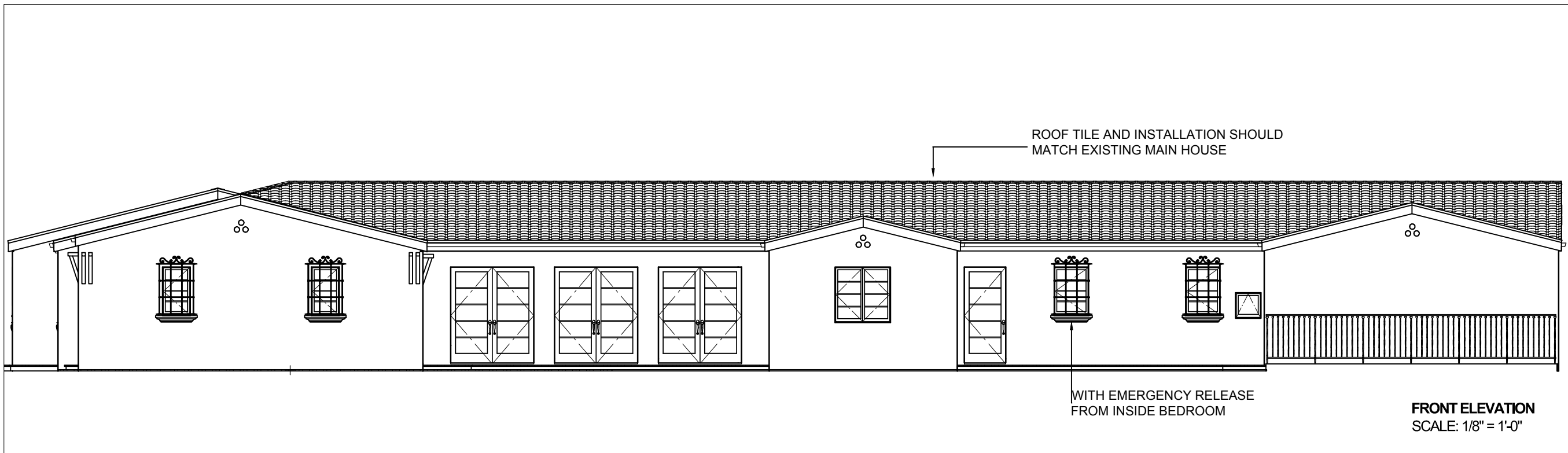

CONCEPT IMAGE
SCALE: NOT TO SCALE



PixelArch Ltd.

Canada main office:
3313 Plateau Blvd.
Coquitlam BC V3E 3B8
+1 604 243 3666

US Office:
1442 N. Dale Ave.
Anaheim, CA 92801
+1 310 734 8517

Toll free: 1 844 729 0009
Email: info@pixelarchpro.com

GENERAL NOTE

All measurements to be verified on site by contractor.

REVISED:
January 10, 2017

DATE:
04.12.2016

COPYRIGHT

THIS DRAWING IS AN INSTRUMENT OF SERVICE AND AS SUCH, REMAINS THE PROPERTY OF PIXELARCH LTD. PERMISSION FOR USE OR REPRODUCTION IS LIMITED AND CAN BE EXTENDED ONLY BY WRITTEN PERMISSION WITH OWNER, PIXELARCH LTD.

No.	Revision/Issue	Date

Firm Name and Address

Darren Asad Architect
darrenasad@mail.com

Project Name and Address

901 N BEDFORD DR. BEVERLY HILLS, CA

DRAWING: GIRLS BATH 1	Sheet
Date January 10, 2017	o OF o
Scale 3/8" = 1' - 00"	A100

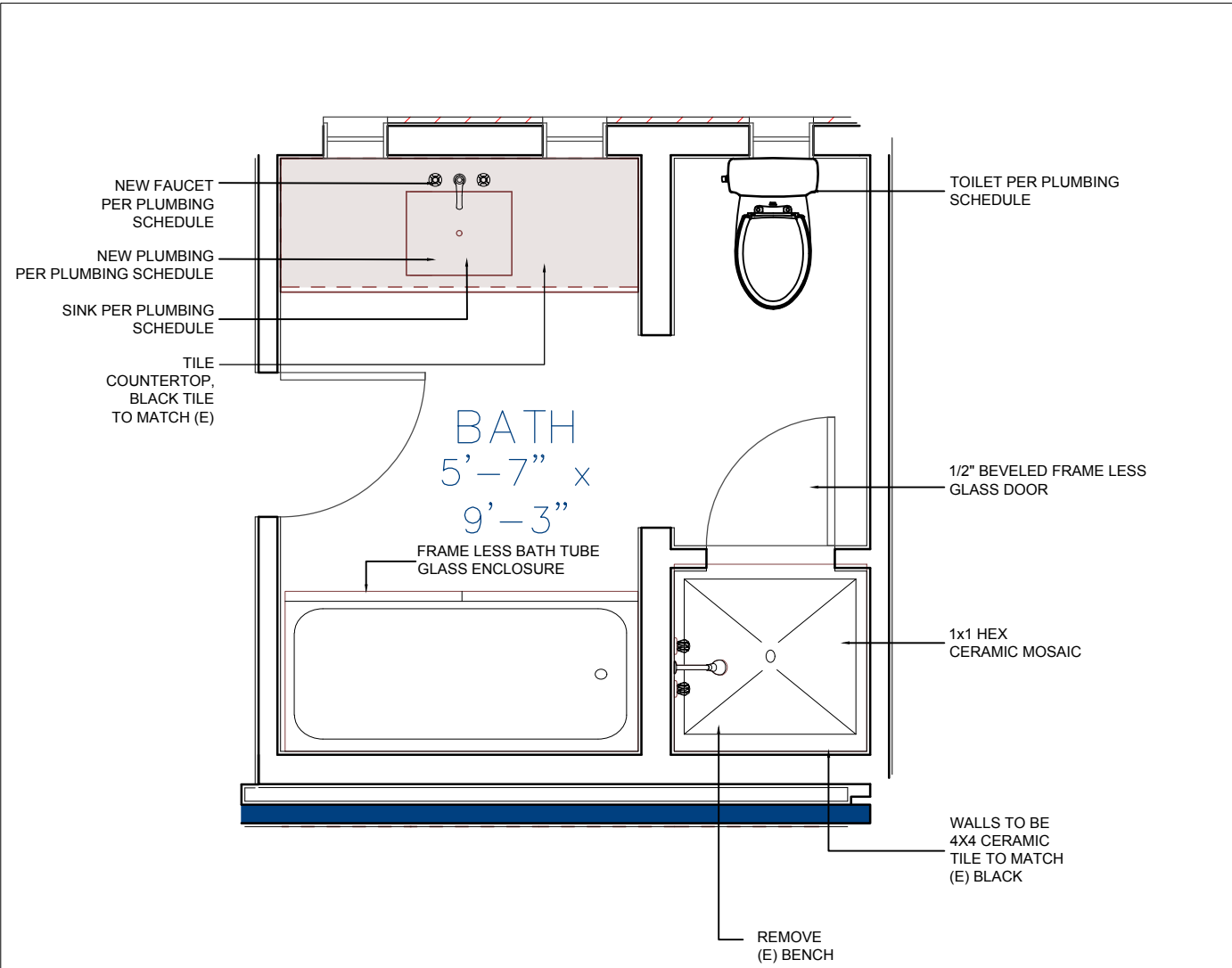

FLOOR PLAN

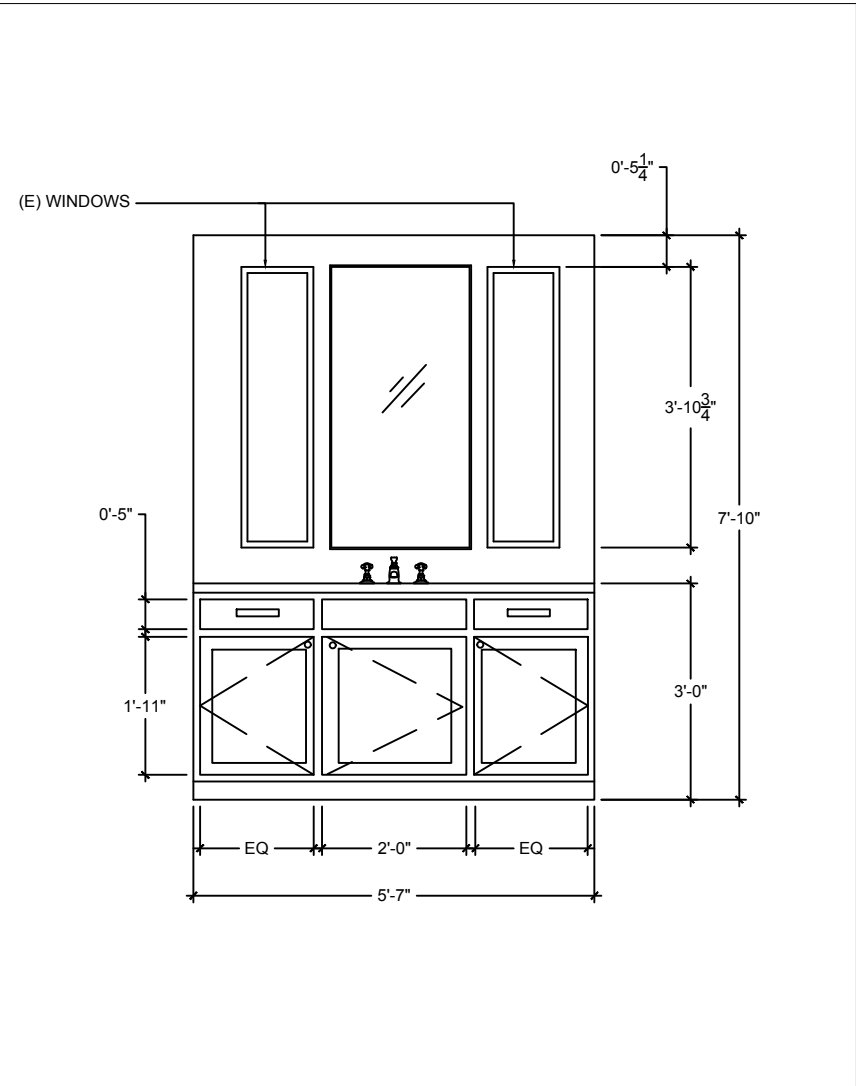

ELEVATION

****NOTE:**
CABINETRY TO BE PAINT FINISH

COUNTER TO BE 4x4 CERAMIC TILE

SINK TO BE BORDERED IN TRIM



PixelArch Ltd.

Canada main office:
3313 Plateau Blvd.
Coquitlam BC V3J 3B8
+1 604 243 3666

US Office:
1442 N. Dale Ave.
Anaheim, CA 92801
+1 310 734 8517

Toll free: 1 844 729 0009
Email: info@pixelarchpro.com

GENERAL NOTE

All measurements to be verified on site by contractor.

REVISED:
January 10, 2017

DATE:
08.04.2016

COPYRIGHT

THIS DRAWING IS AN INSTRUMENT OF SERVICE AND AS SUCH, REMAINS THE PROPERTY OF PIXELARCH LTD. PERMISSION FOR USE OR REPRODUCTION IS LIMITED AND CAN BE EXTENDED ONLY BY WRITTEN PERMISSION WITH OWNER, PIXELARCH LTD.

No.	Revision/Issue	Date

Firm Name and Address

Darren Asad Architect
darrenasad@mail.com

Project Name and Address

901 N BEDFORD DR. BEVERLY HILLS, CA

DRAWING: GIRLS BATH 2	Sheet o OF o
Date January 10, 2017	A100
Scale 3/8" = 1' - 00"	

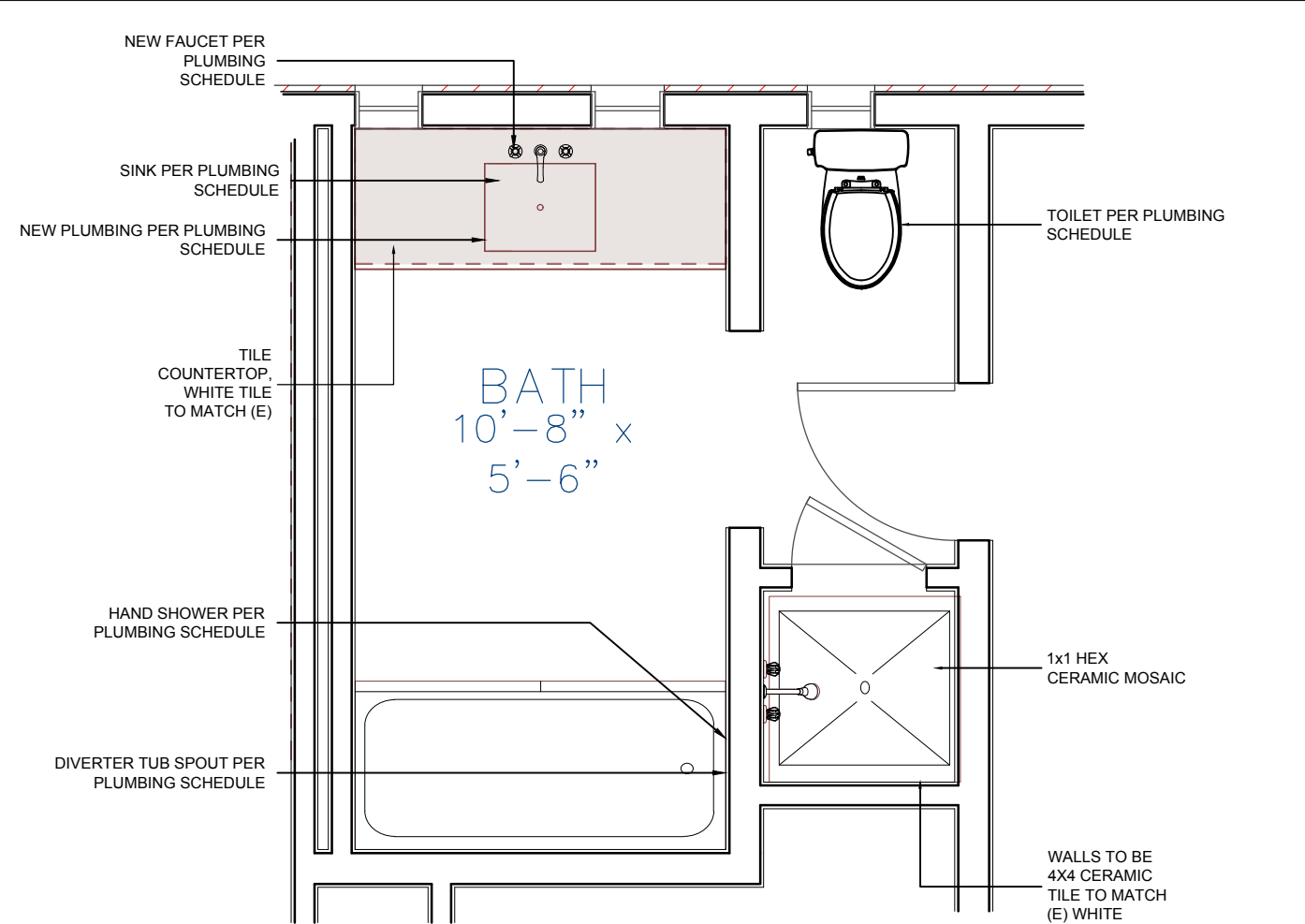

FLOOR PLAN

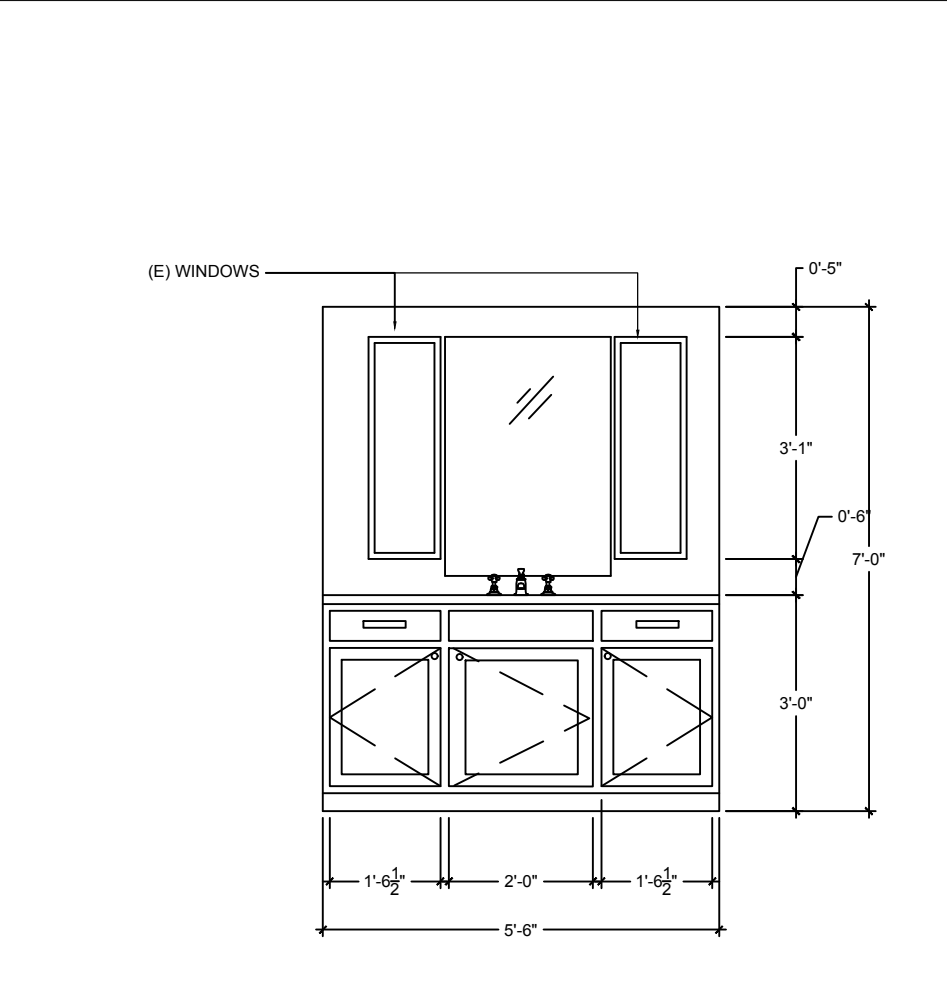

ELEVATION 1

****NOTE:**
CABINERY TO BE PAINT FINISH

COUNTER TO BE 4x4 PORCELAIN TILE

SINK TO BE BORDERED IN TRIM



PixelArch Ltd.

Canada main office:
3313 Plateau Blvd.
Coquitlam BC V3E 3B8
+1 604 243 3666

US Office:
1442 N. Dale Ave.
Anaheim, CA 92801
+1 310 734 8517

Toll free: 1 844 729 0009
Email: info@pixelarchpro.com

GENERAL NOTE

All measurements to be verified on site by contractor.

REVISED:
January 10, 2017

DATE:
07.06.2016

COPYRIGHT

THIS DRAWING IS AN INSTRUMENT OF SERVICE AND AS SUCH, REMAINS THE PROPERTY OF PIXELARCH LTD. PERMISSION FOR USE OR REPRODUCTION IS LIMITED AND CAN BE EXTENDED ONLY BY WRITTEN PERMISSION WITH OWNER, PIXELARCH LTD.

No.	Revision/Issue	Date

Firm Name and Address

Darren Asad Architect
darrenasad@mail.com

Project Name and Address

901 N BEDFORD DR. BEVERLY HILLS, CA

DRAWING: GIRLS BATH 2 TILE ELEVATION	Sheet 0 OF 0
Date January 10, 2017	A100
Scale 3/8" = 1' - 00"	

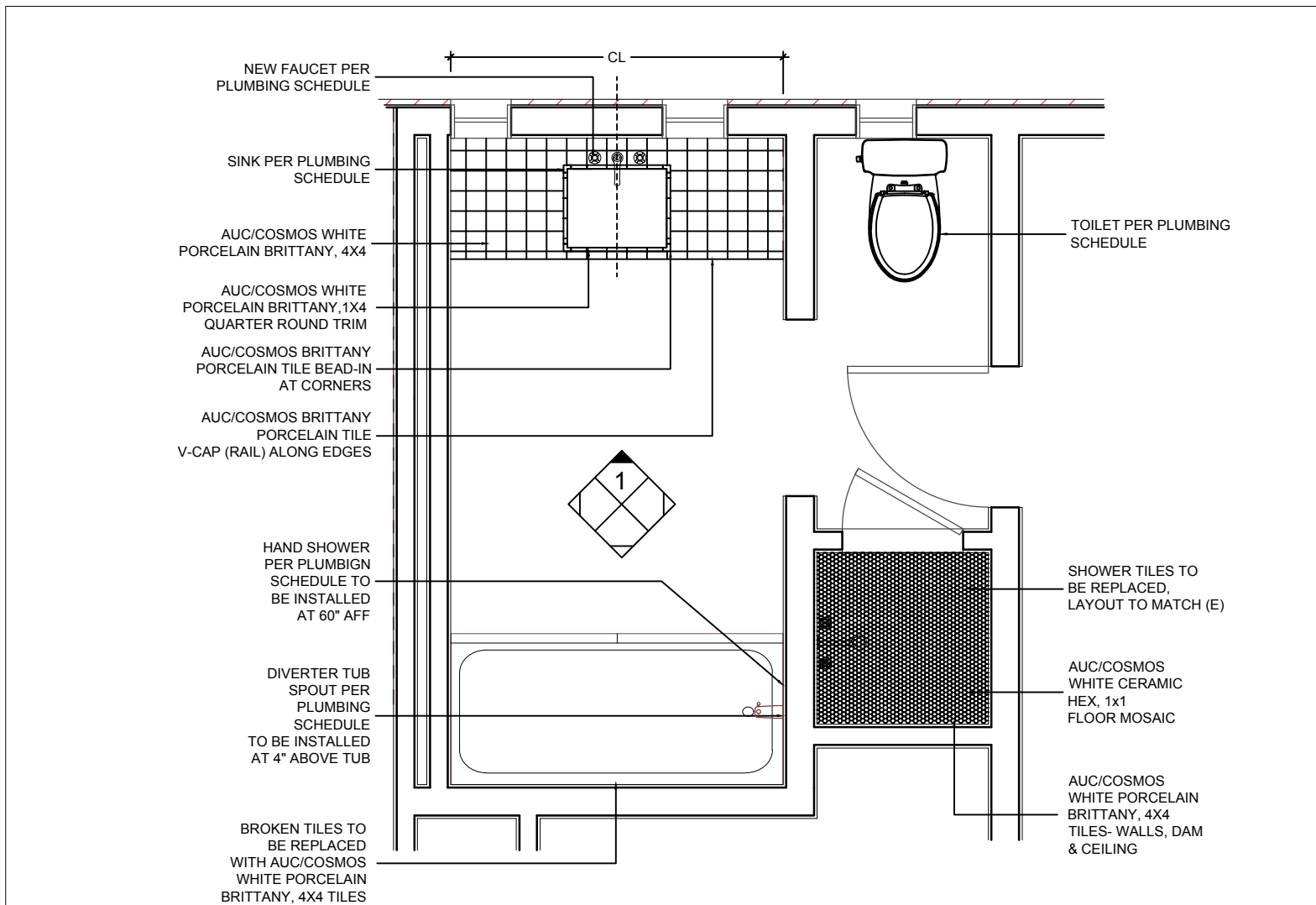

FLOOR PLAN

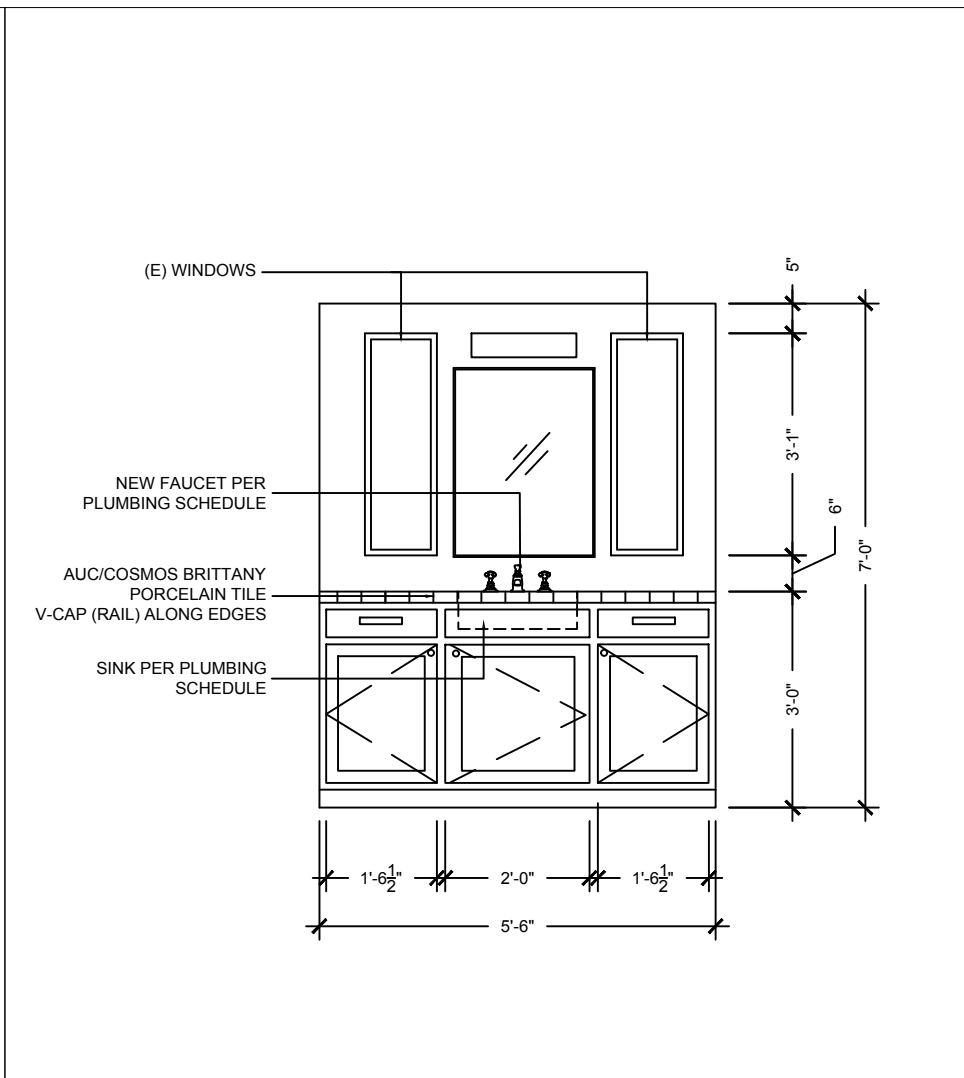

ELEVATION 1

****NOTE:**
CABINETRY TO BE PAINT FINISH

COUNTER TO BE 4x4 PORCELAIN TILE

SINK TO BE BORDERED IN TRIM



PixelArch Ltd.

Canada main office:
3313 Plateau Blvd.
Coquitlam BC V3E 3B8
+1 604 243 3666

US Office:
1442 N. Dale Ave.
Anaheim, CA 92801
+1 310 734 8517

Toll free: 1 844 729 0009
Email: info@pixelarchpro.com

GENERAL NOTE

All measurements to be verified on site by contractor.

REVISED:
January 10, 2017

DATE:
05.03.2016

COPYRIGHT

THIS DRAWING IS AN INSTRUMENT OF SERVICE AND AS SUCH, REMAINS THE PROPERTY OF PIXELARCH LTD. PERMISSION FOR USE OR REPRODUCTION IS LIMITED AND CAN BE EXTENDED ONLY BY WRITTEN PERMISSION WITH OWNER, PIXELARCH LTD.

No.	Revision/Issue	Date

Firm Name and Address

Darren Asad Architect
darrenasad@mail.com

Project Name and Address

901 N BEDFORD DR. BEVERLY HILLS, CA

DRAWING: MASTER SHOWER TILE	Sheet 0 OF 0
Date January 10, 2017	A100
Scale NTS	

****NOTE:**
COUNTERS AND BENCH TO BE SLAB
EXTERIOR DECORATIVE HINGES
CENTER OF SHOWERHEAD TO BE 7'
CENTER OF HANDHELD SHOWERHEAD TO BE 56"
CENTER OF VALVES TO BE AT 45"
SHOWER DOOR TO BE 1/2" FRAME LESS GLASS

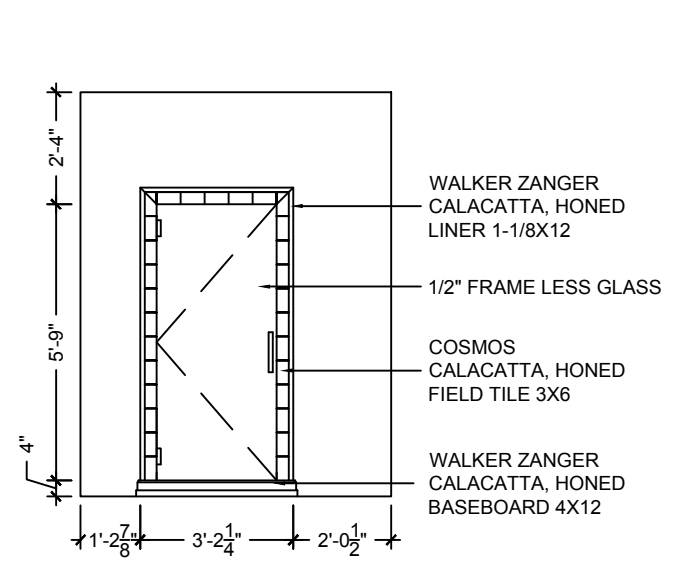

ELEVATION 1

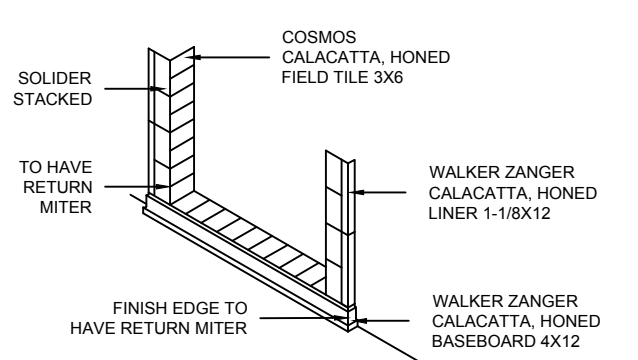

OUTSIDE SHOWER DOOR NOT TO SCALE

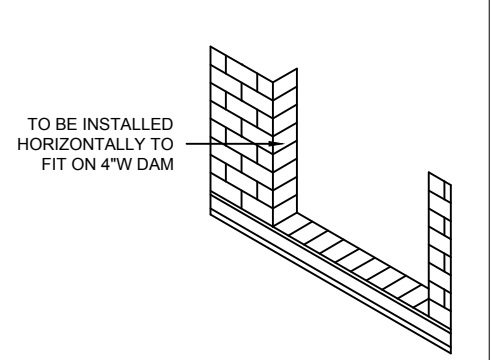

INSIDE SHOWER DOOR NOT TO SCALE

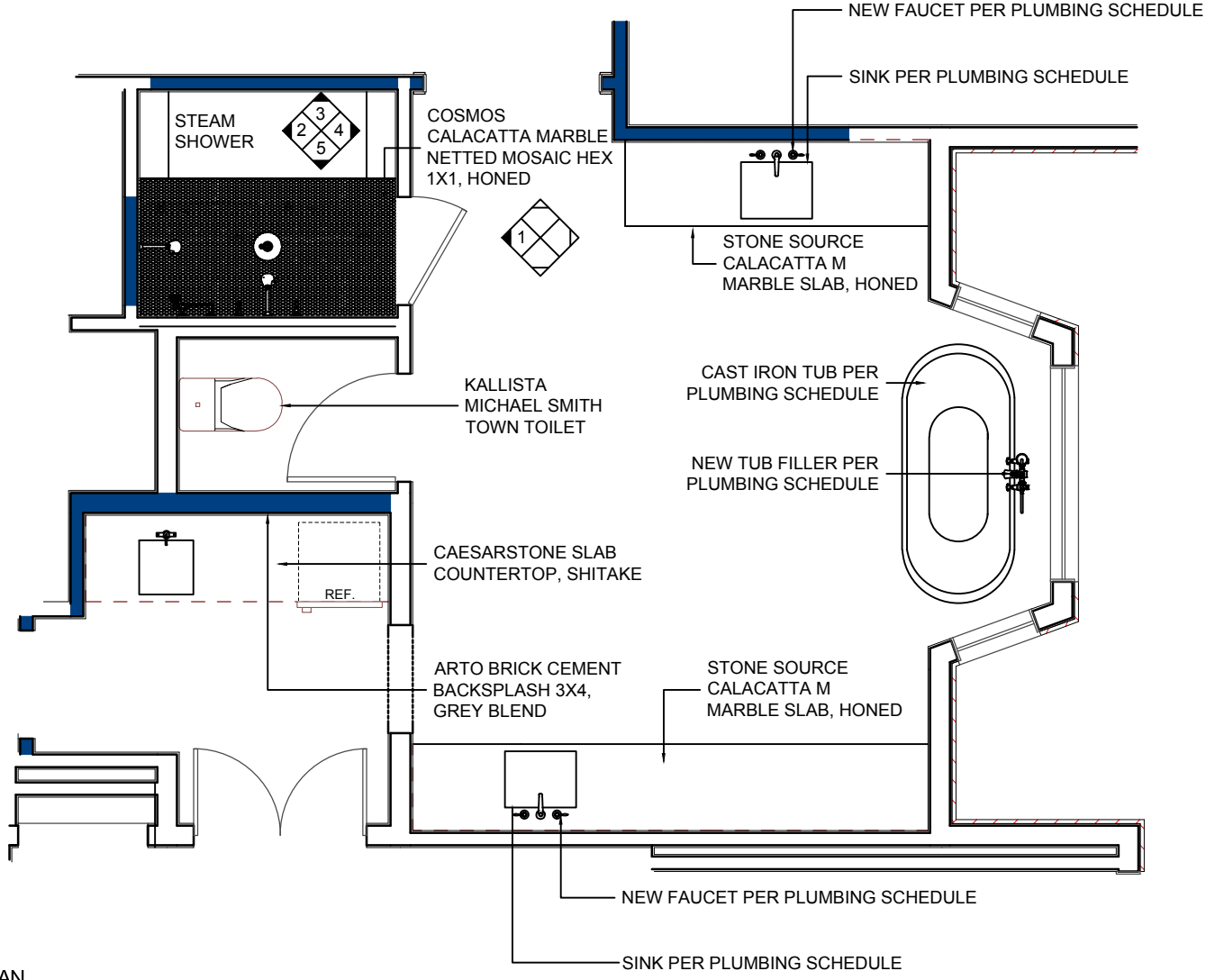

FLOOR PLAN

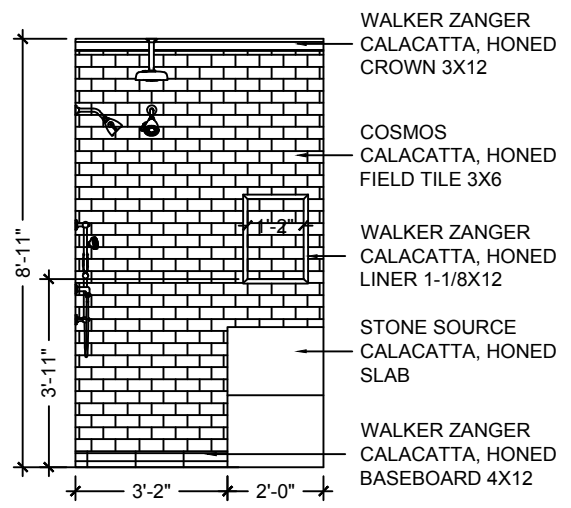

ELEVATION 2

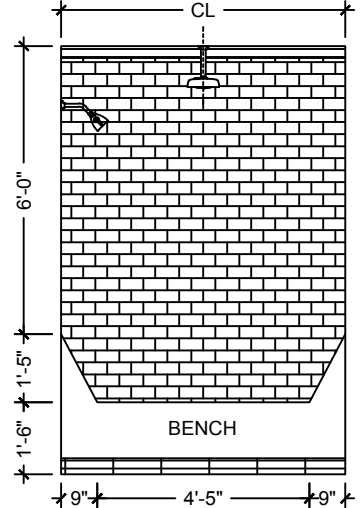

ELEVATION 3

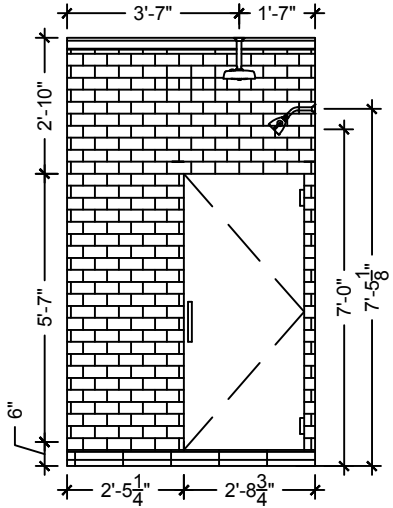

ELEVATION 4

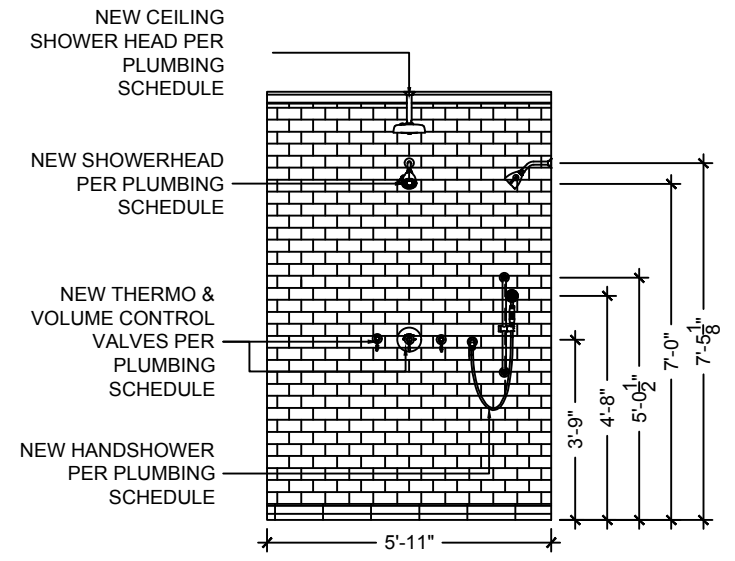

ELEVATION 5



PixelArch Ltd.

Canada main office:
3313 Plateau Blvd.
Coquitlam BC V3E 3B8
+1 604 243 3666

US Office:
1442 N. Dale Ave.
Anaheim, CA 92801
+1 310 734 8517
Toll free: 1 844 729 0009
Email: info@pixelarchpro.com

GENERAL NOTE

All measurements to be verified on site by contractor.

REVISED:
January 10, 2017

DATE:
06.16.2016

COPYRIGHT

THIS DRAWING IS AN INSTRUMENT OF SERVICE AND AS SUCH, REMAINS THE PROPERTY OF PIXELARCH LTD. PERMISSION FOR USE OR REPRODUCTION IS LIMITED AND CAN BE EXTENDED ONLY BY WRITTEN PERMISSION WITH OWNER, PIXELARCH LTD.

No.	Revision/Issue	Date

Firm Name and Address

Darren Asad Architect
darrenasad@mail.com

Project Name and Address

901 N BEDFORD DR. BEVERLY HILLS, CA

DRAWING: LAUNDRY ROOM Date January 10, 2017 Scale 1/2" = 1' - 00"	Sheet 0 OF 0 A100
--	--------------------------------

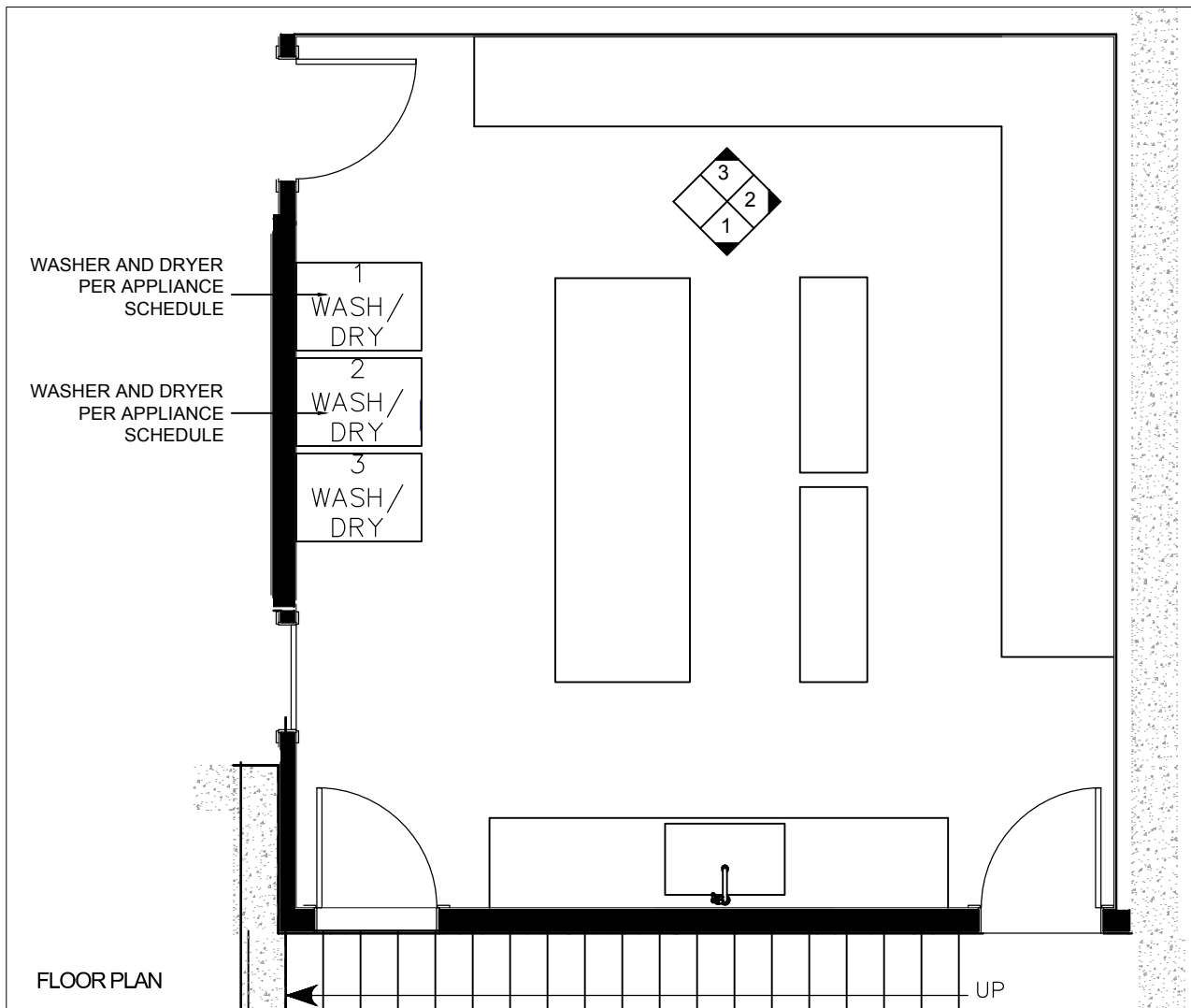

ELEVATION 1

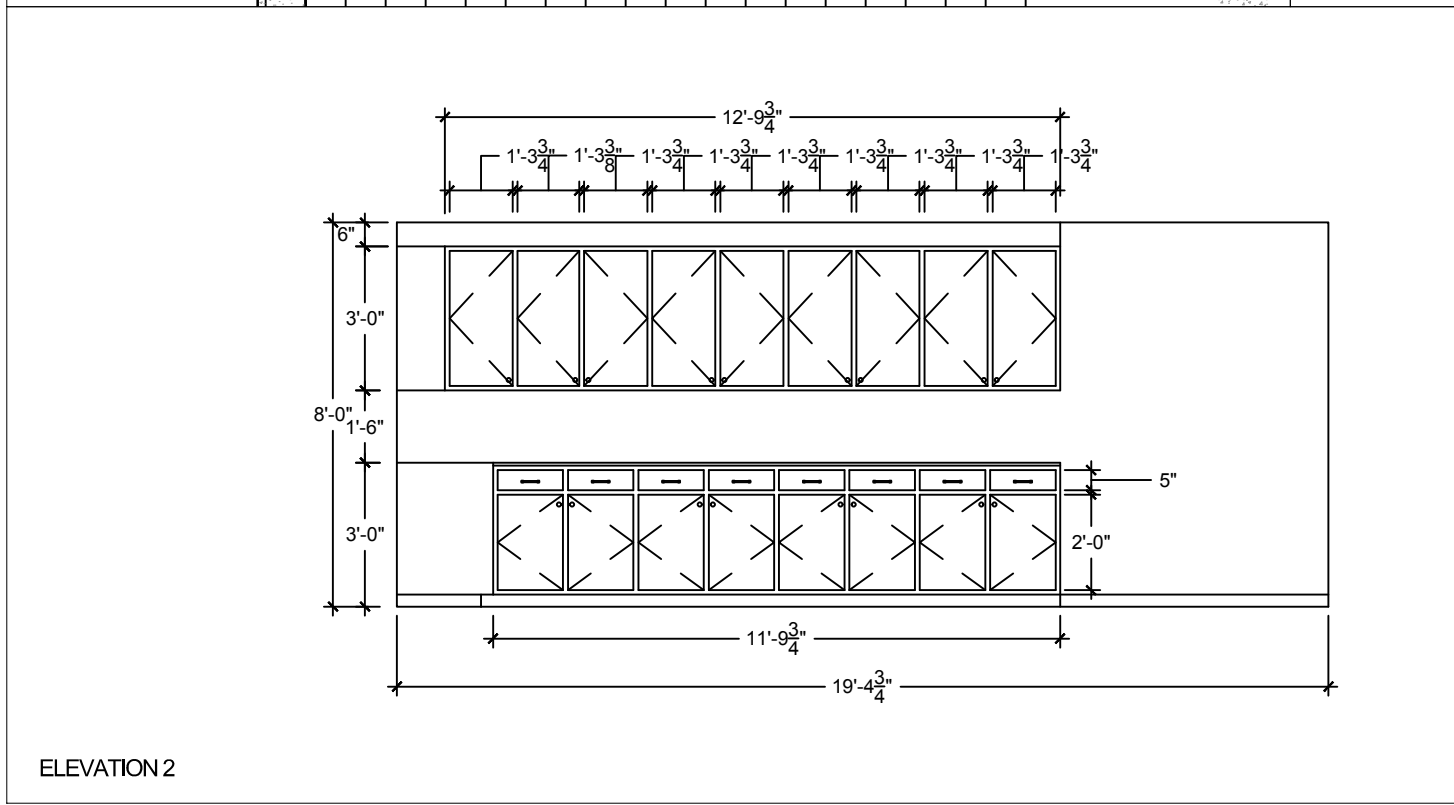
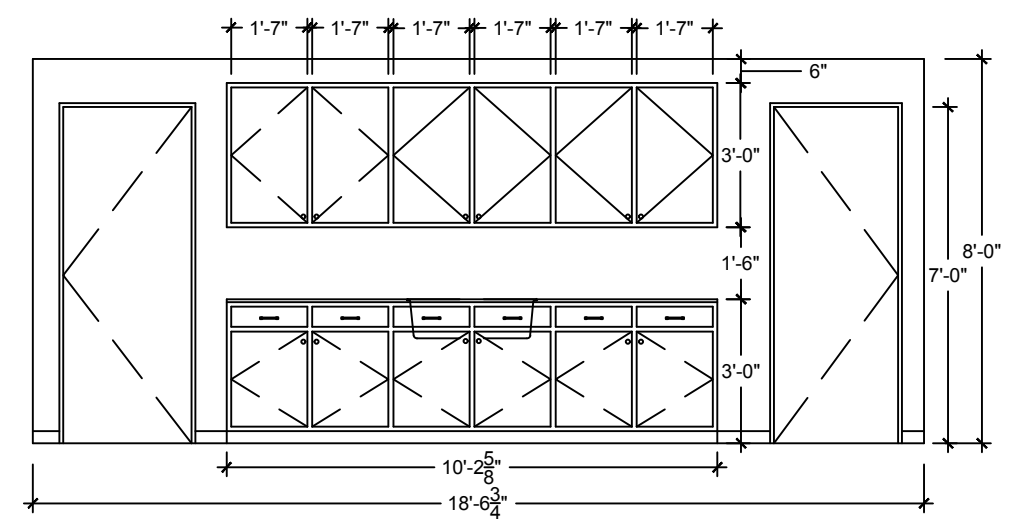

ELEVATION 2

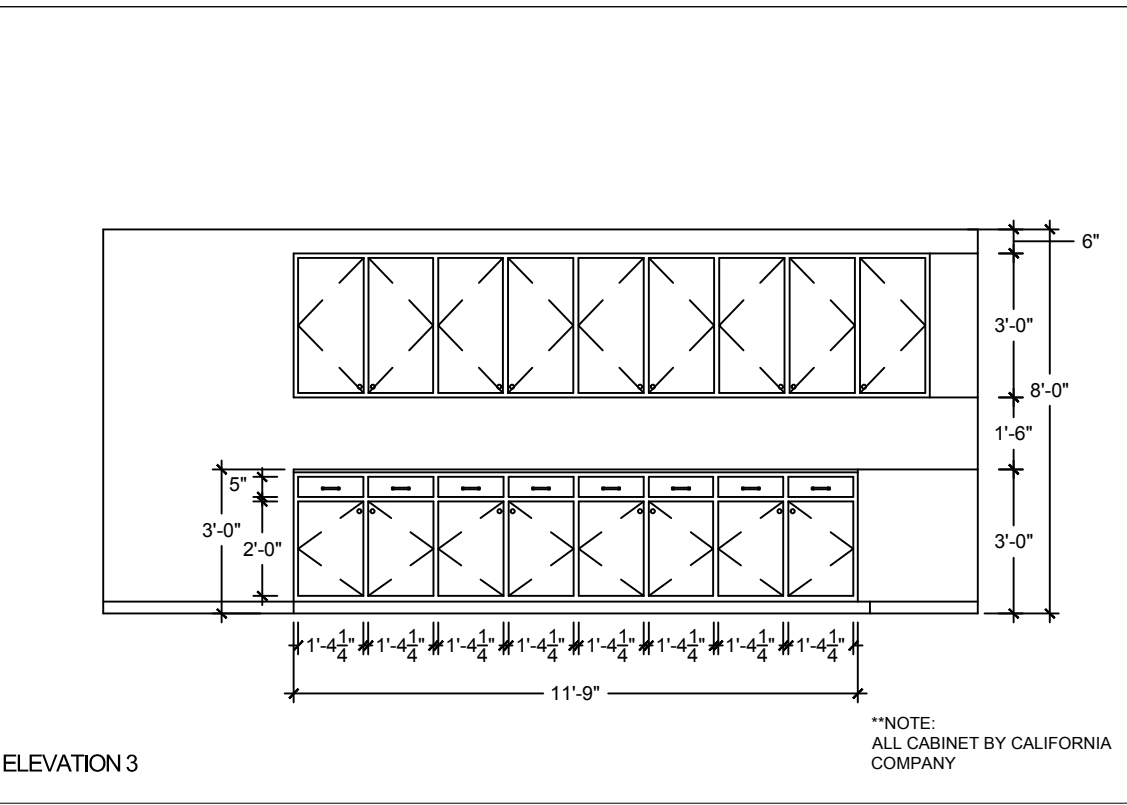

ELEVATION 3

**NOTE:
ALL CABINET BY CALIFORNIA COMPANY



PixelArch Ltd.

Canada main office:
3313 Plateau Blvd.
Coquitlam BC V3E 3B8
+1 604 243 3666

US Office:
1442 N. Dale Ave.
Anaheim, CA 92801
+1 310 734 8517

Toll free: 1 844 729 0009
Email: info@pixelarchpro.com

GENERAL NOTE

All measurements to be verified on site by contractor.

REVISED:
January 10, 2017

DATE:
05.26.2016

COPYRIGHT

THIS DRAWING IS AN INSTRUMENT OF SERVICE AND AS SUCH, REMAINS THE PROPERTY OF PIXELARCH LTD. PERMISSION FOR USE OR REPRODUCTION IS LIMITED AND CAN BE EXTENDED ONLY BY WRITTEN PERMISSION WITH OWNER, PIXELARCH LTD.

No.	Revision/Issue	Date

Firm Name and Address

Darren Asad Architect
darrenasad@mail.com

Project Name and Address

901 N BEDFORD DR. BEVERLY HILLS, CA

DRAWING:
JONATHAN'S BATH ELEVATIONS
Date:
January 10, 2017
Scale:
3/8" = 1' - 00"

Sheet
0 OF 0
A100

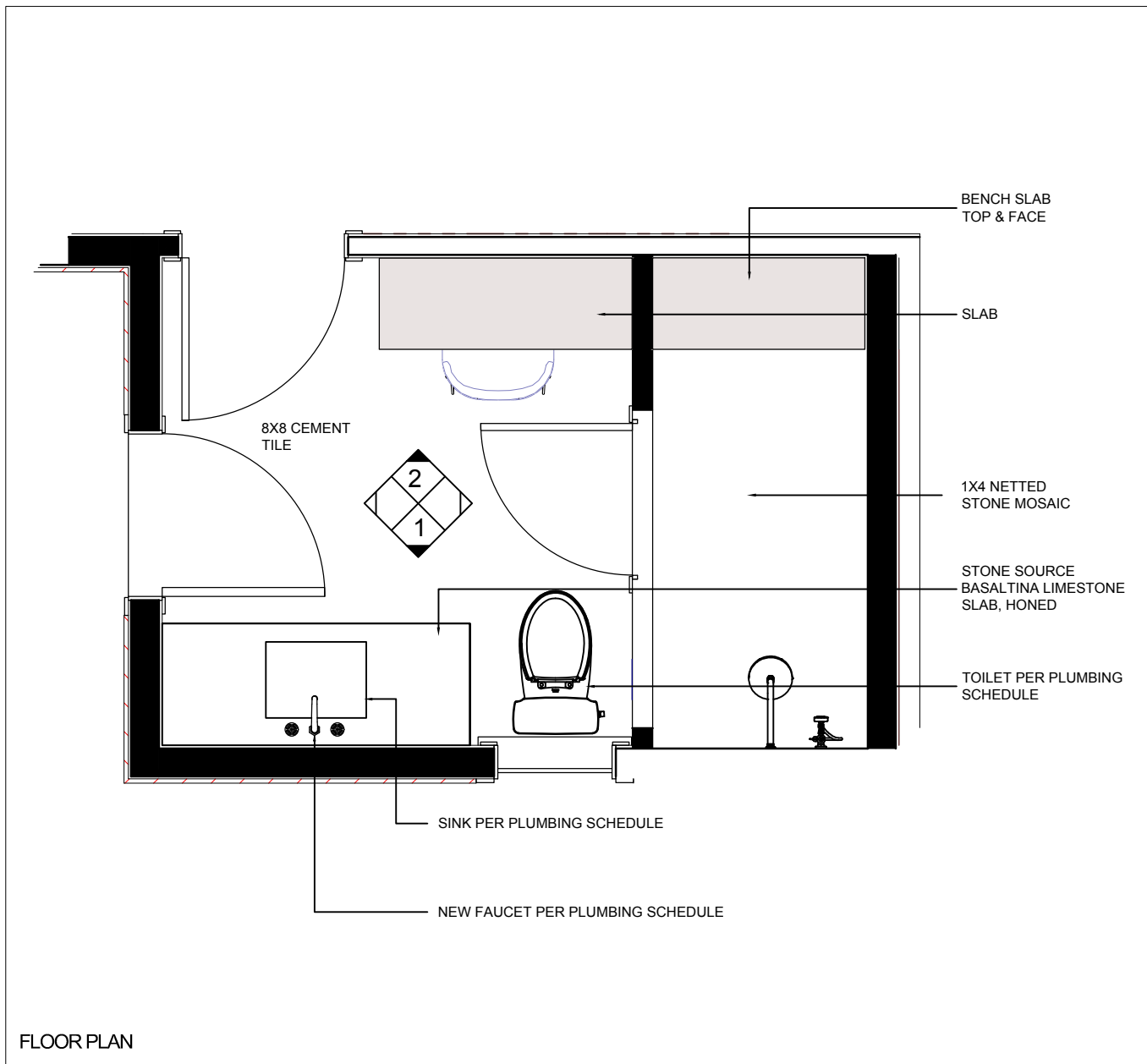

ELEVATION 1

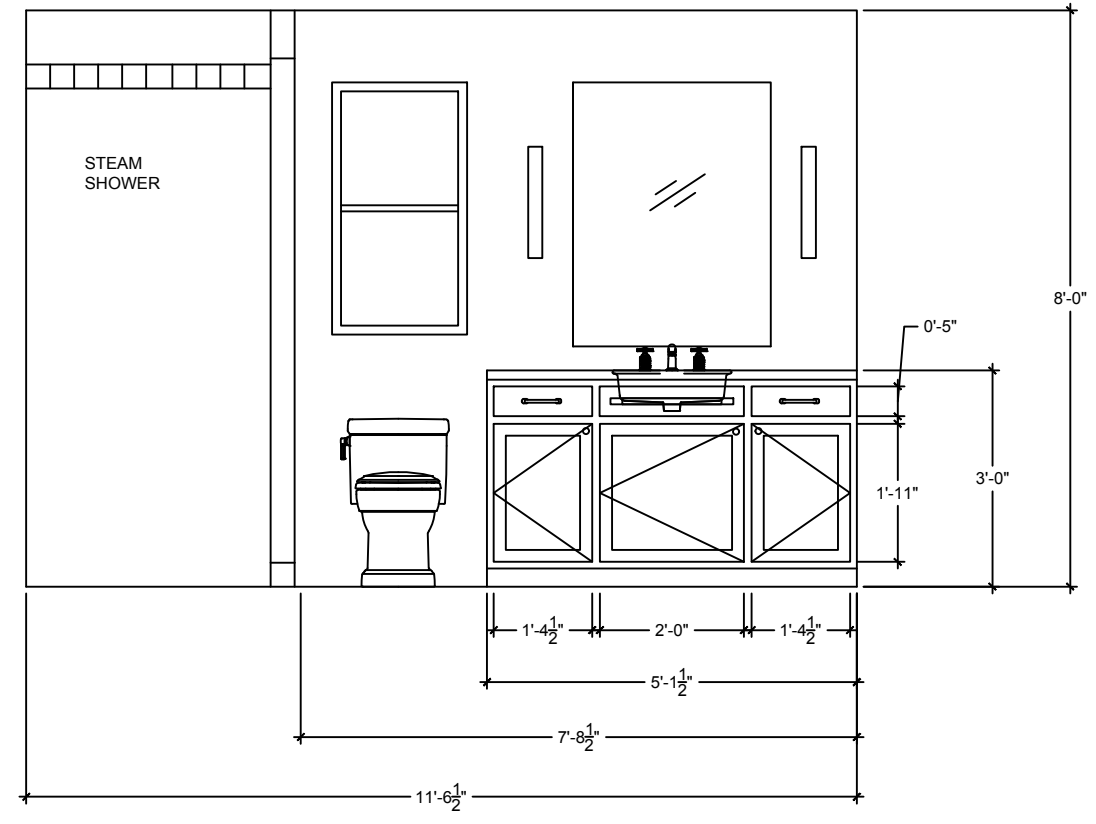

ELEVATION 2

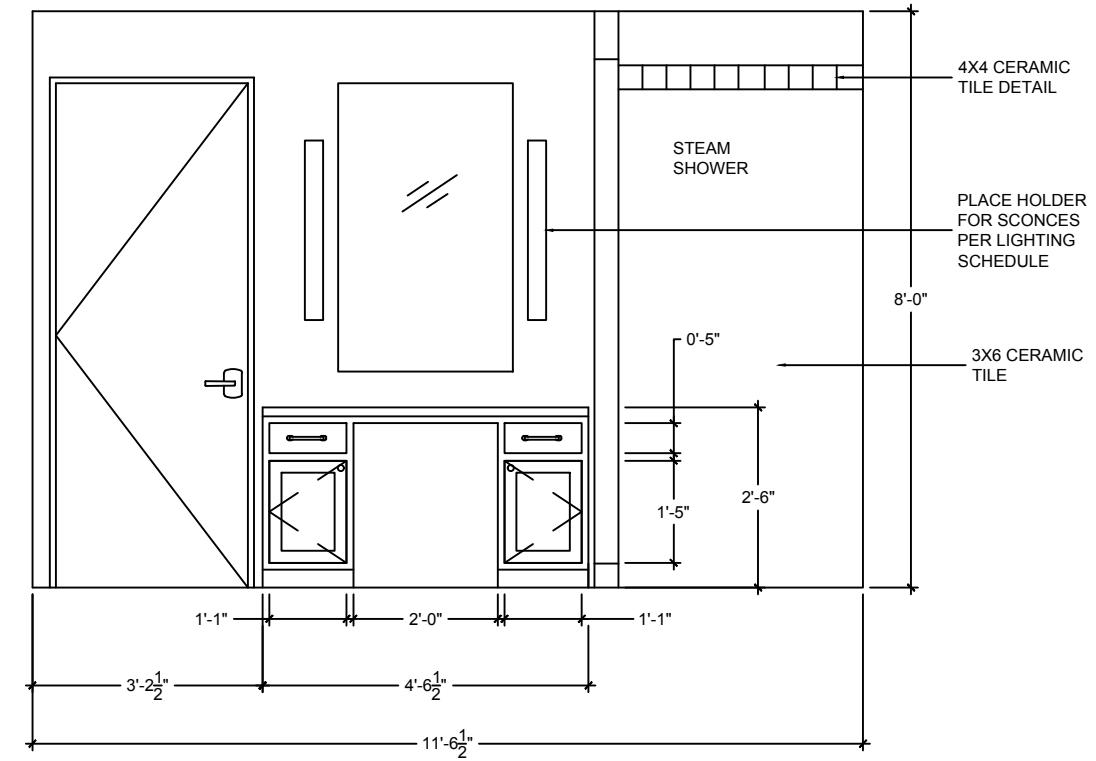

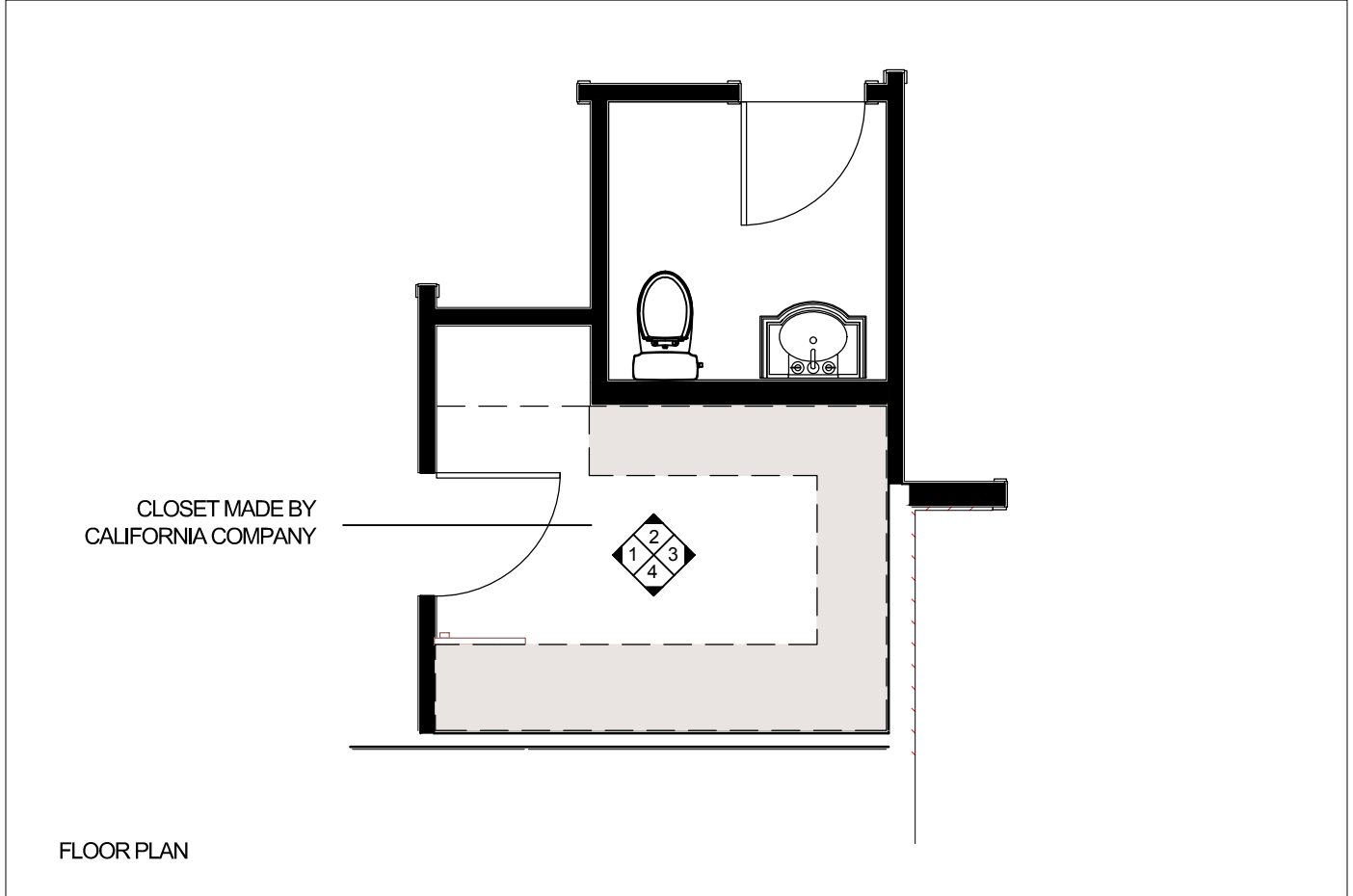

PixelArch Ltd.

Canada main office:
3313 Plateau Blvd.
Coquitlam BC V3E 3B8
+1 604 243 3666

US Office:
1442 N. Dale Ave.
Anaheim, CA 92801
+1 310 734 8517

Toll free: 1 844 729 0009
Email: info@pixelarchpro.com

GENERAL NOTE

All measurements to be verified on site by contractor.

REVISED:
January 10, 2017

DATE:
06.26.2016

COPYRIGHT

THIS DRAWING IS AN INSTRUMENT OF SERVICE AND AS SUCH, REMAINS THE PROPERTY OF PIXELARCH LTD. PERMISSION FOR USE OR REPRODUCTION IS LIMITED AND CAN BE EXTENDED ONLY BY WRITTEN PERMISSION WITH OWNER, PIXELARCH LTD.

No.	Revision/Issue	Date

Firm Name and Address

Darren Asad Architect
darrenasad@mail.com

Project Name and Address

901 N BEDFORD DR. BEVERLY HILLS, CA

DRAWING: JONATHAN'S CLOSET	Sheet 0 OF 0
Date January 10, 2017	A100
Scale 1/4" = 1' - 00"	



PixelArch Ltd.

Canada main office:
3313 Plateau Blvd.
Coquitlam BC V3E 3B8
+1 604 243 3666

US Office:
1442 N. Dale Ave.
Anaheim, CA 92801
+1 310 734 8517
Toll free: 1 844 729 0009
Email: info@pixelarchpro.com

GENERAL NOTE

All measurements to be verified on site by contractor.

REVISED:
January 10, 2017

DATE:
05.26.2016

COPYRIGHT

THIS DRAWING IS AN INSTRUMENT OF SERVICE AND AS SUCH, REMAINS THE PROPERTY OF PIXELARCH LTD. PERMISSION FOR USE OR REPRODUCTION IS LIMITED AND CAN BE EXTENDED ONLY BY WRITTEN PERMISSION WITH OWNER, PIXELARCH LTD.

No.	Revision/Issue	Date

Firm Name and Address

Darren Asad Architect
darrenasad@mail.com

Project Name and Address

901 N BEDFORD DR. BEVERLY HILLS, CA

DRAWING:
MOM'S BATH TILE ELEVATION
Date
January 10, 2017
Scale
3/8" = 1' - 00"

Sheet
0 OF 0
A100

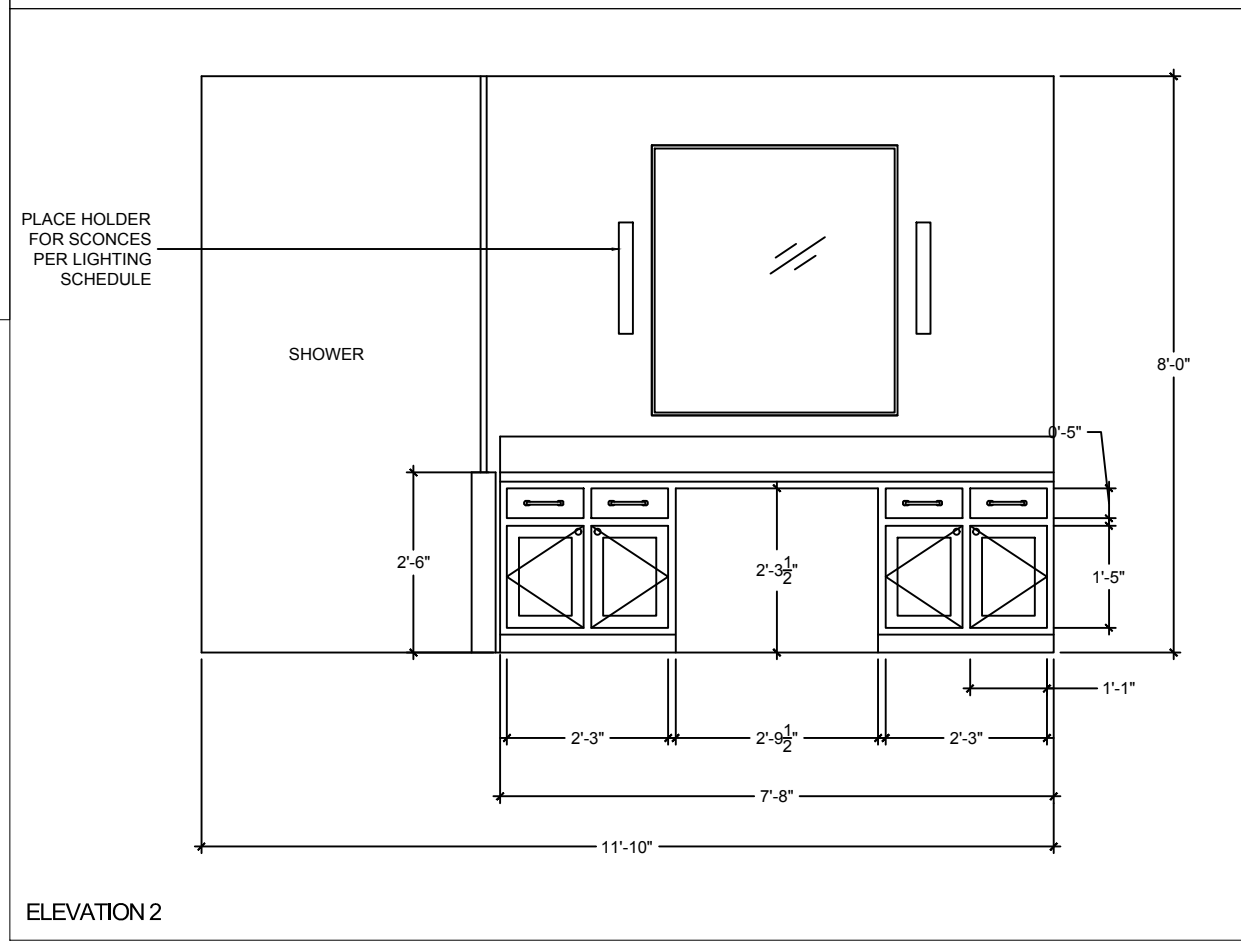
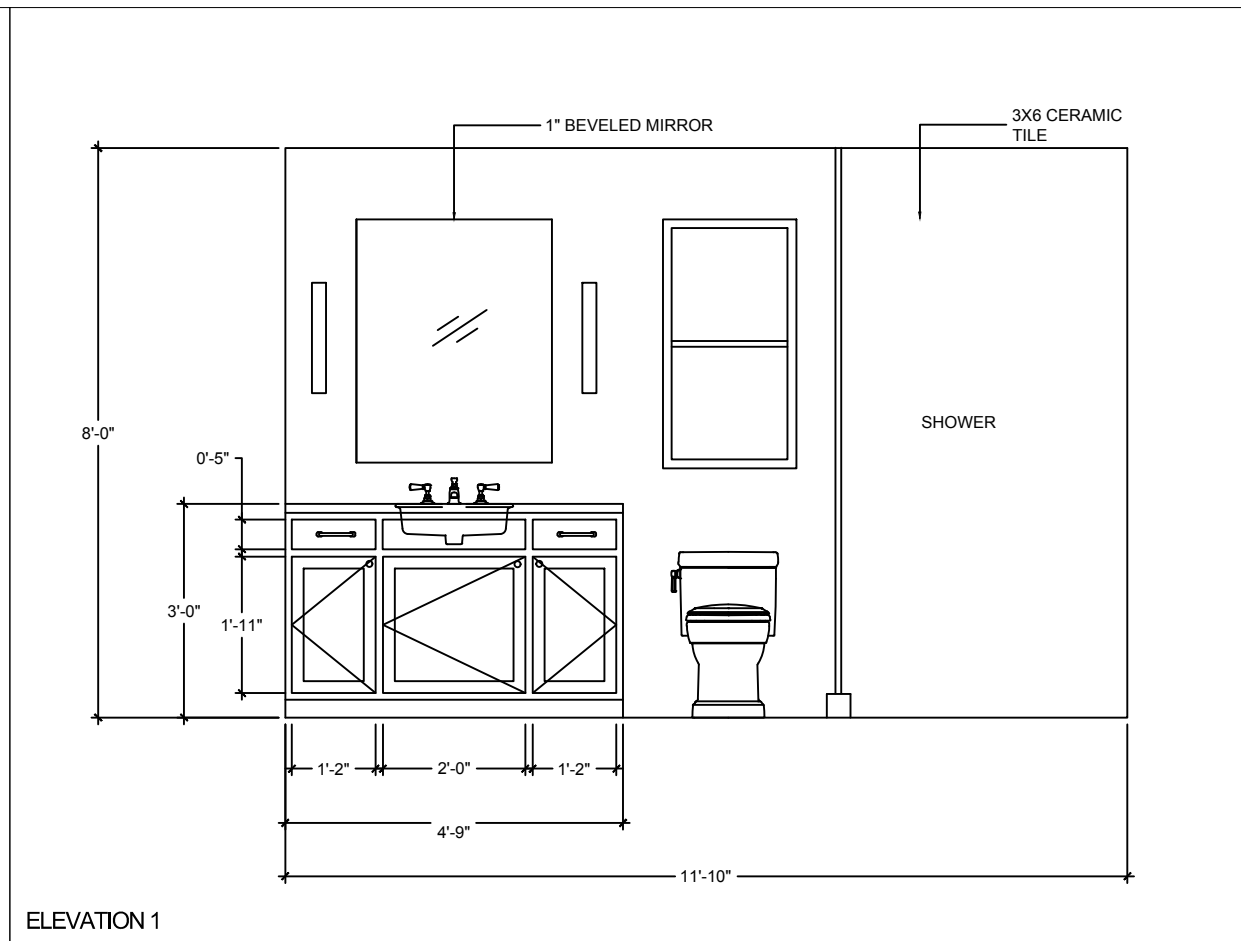
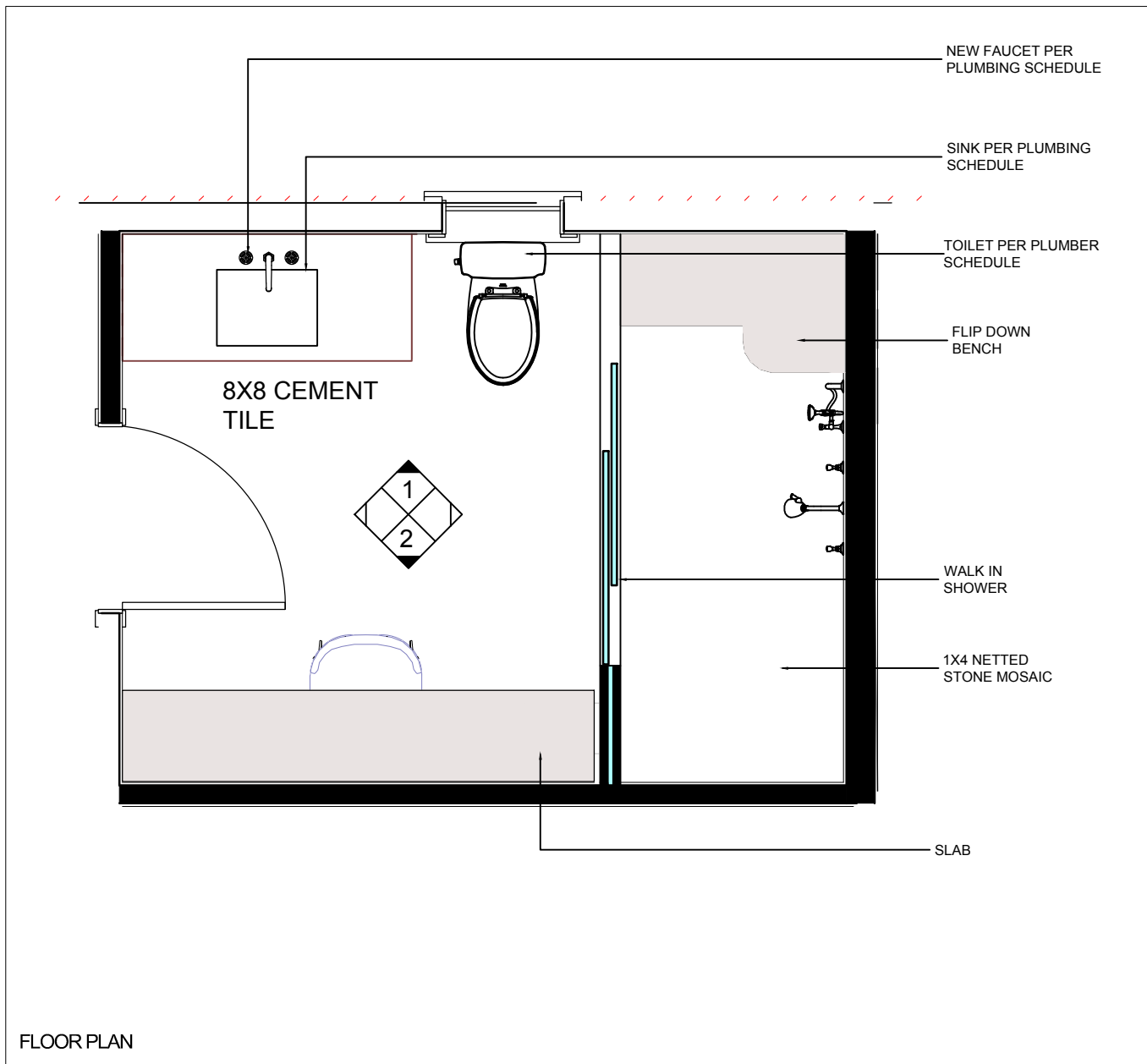

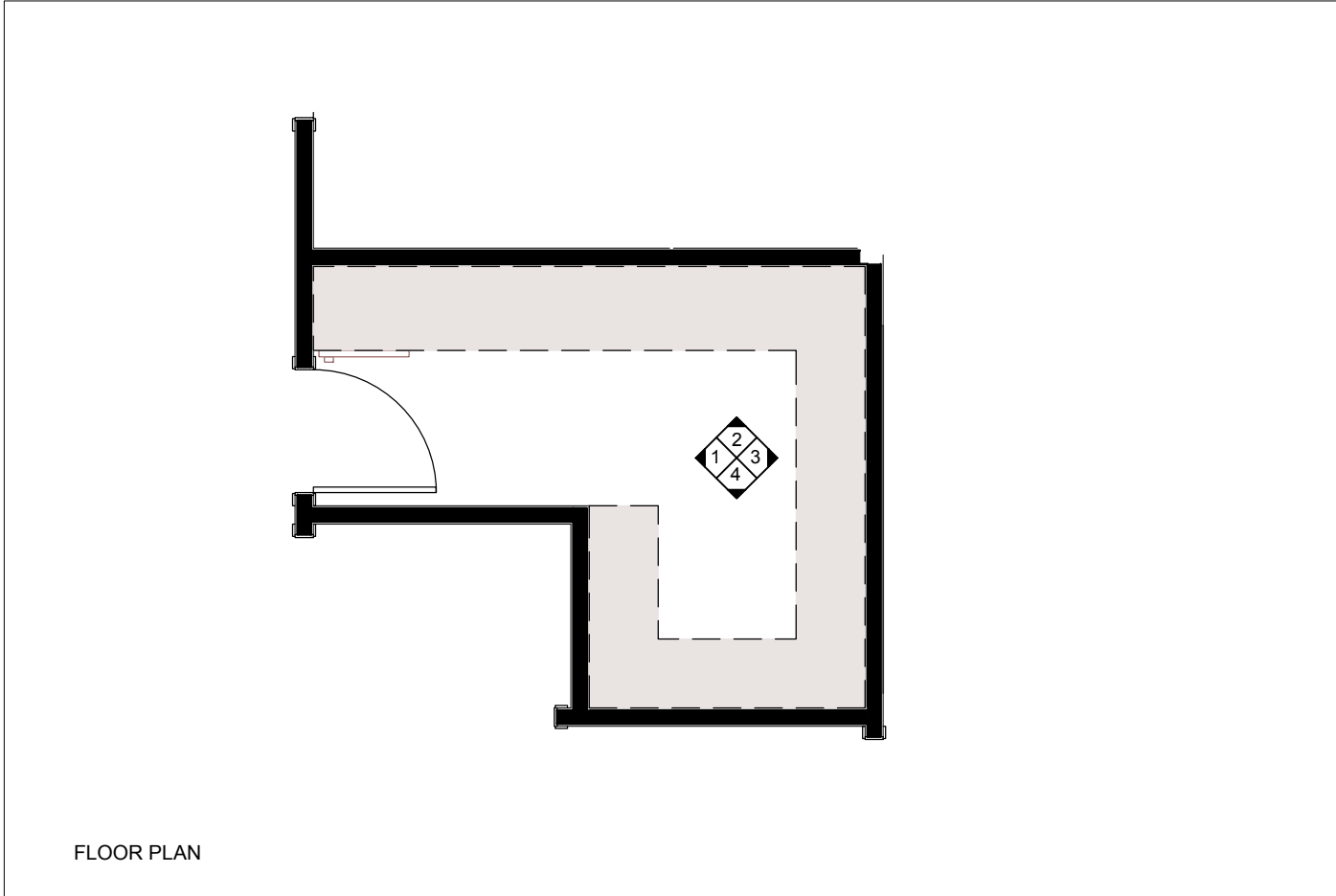

FLOOR PLAN

****NOTE:**
CLOSET BY CALIFORNIA
COMPANY



PixelArch Ltd.

Canada main office:
3313 Plateau Blvd.
Coquitlam BC V3E 3B8
+1 604 243 3666

US Office:
1442 N. Dale Ave.
Anaheim, CA 92801
+1 310 734 8517

Toll free: 1 844 729 0009
Email: info@pixelarchpro.com

GENERAL NOTE

All measurements to be verified on site by contractor.

REVISED:
January 10, 2017

DATE:
06.26.2016

COPYRIGHT

THIS DRAWING IS AN INSTRUMENT OF SERVICE AND AS SUCH, REMAINS THE PROPERTY OF PIXELARCH LTD. PERMISSION FOR USE OR REPRODUCTION IS LIMITED AND CAN BE EXTENDED ONLY BY WRITTEN PERMISSION WITH OWNER, PIXELARCH LTD.

No.	Revision/Issue	Date

Firm Name and Address

Darren Asad Architect
darrenasad@mail.com

Project Name and Address

901 N BEDFORD DR. BEVERLY HILLS, CA

DRAWING: MOM'S CLOSET	Sheet 0 OF 0
Date January 10, 2017	A100
Scale 1/4" = 1' - 00"	

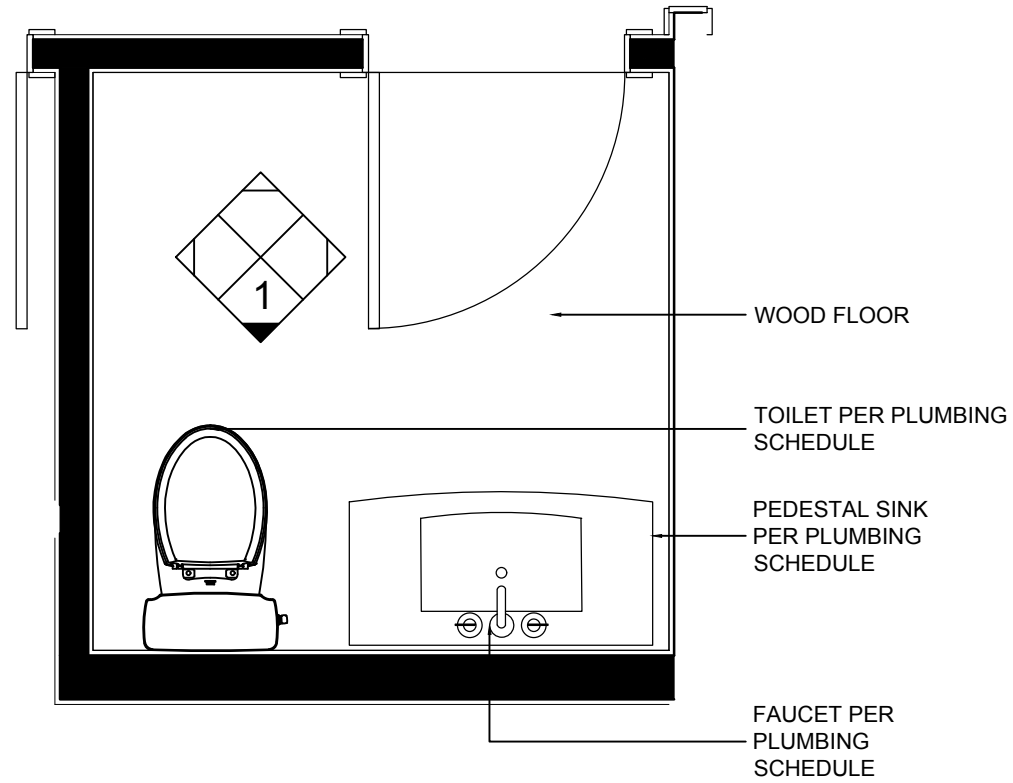

FLOOR PLAN

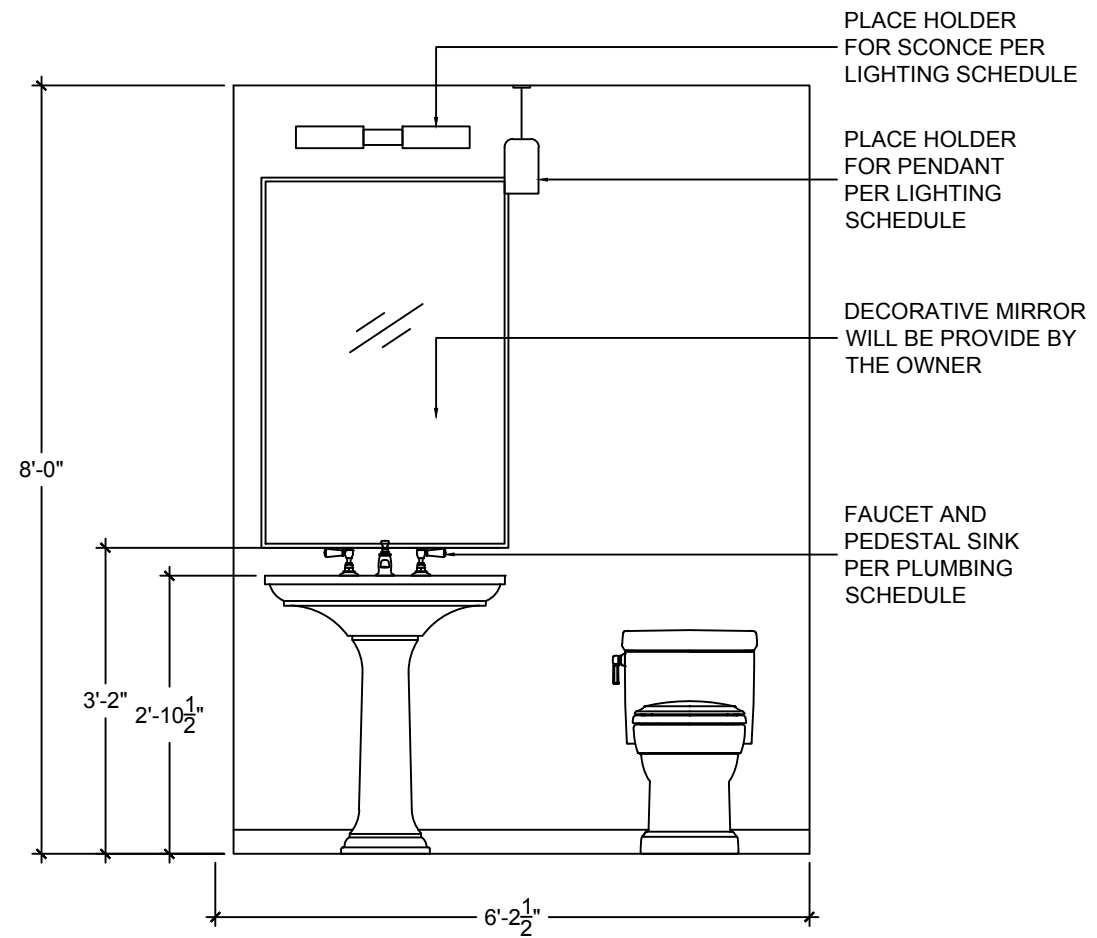

ELEVATION 1



PixelArch Ltd.
 Canada main office:
 3313 Plateau Blvd.
 Coquitlam BC V3E 3B8
 +1 604 243 3666

US Office:
 1442 N. Dale Ave.
 Anaheim, CA 92801
 +1 310 734 8517
 Toll free: 1 844 729 0009
 Email: info@pixelarchpro.com

GENERAL NOTE

All measurements to be verified on site by contractor.

REVISED:
 January 10, 2017

DATE:
 05.26.2016

COPYRIGHT

THIS DRAWING IS AN INSTRUMENT OF SERVICE AND AS SUCH, REMAINS THE PROPERTY OF PIXELARCH LTD. PERMISSION FOR USE OR REPRODUCTION IS LIMITED AND CAN BE EXTENDED ONLY BY WRITTEN PERMISSION WITH OWNER, PIXELARCH LTD.

No.	Revision/Issue	Date

Firm Name and Address

Darren Asad Architect
 darrenasad@mail.com

Project Name and Address

901 N BEDFORD DR. BEVERLY HILLS, CA

DRAWING: POWDER	Sheet
Date January 10, 2017	o OF o
Scale 1/2" = 1' - 00"	A100



PixelArch Ltd.

Canada main office:
3313 Plateau Blvd.
Coquitlam BC V3E 3B8
+1 604 243 3666

US Office:
1442 N. Dale Ave.
Anaheim, CA 92801
+1 310 734 8517

Toll free: 1 844 729 0009
Email: info@pixelarchpro.com

GENERAL NOTE

All measurements to be verified on site by contractor.

REVISED:
January 10, 2017

DATE:
05.03.2016

COPYRIGHT

THIS DRAWING IS AN INSTRUMENT OF SERVICE AND AS SUCH, REMAINS THE PROPERTY OF PIXELARCH LTD. PERMISSION FOR USE OR REPRODUCTION IS LIMITED AND CAN BE EXTENDED ONLY BY WRITTEN PERMISSION WITH OWNER, PIXELARCH LTD.

No.	Revision/Issue	Date

Firm Name and Address

Darren Asad Architect
darrenasad@mail.com

Project Name and Address

901 N BEDFORD DR. BEVERLY HILLS, CA

DRAWING: BAR ELEVATIONS Date January 10, 2017 Scale 1/4" = 1'-00"	Sheet 0 OF 0 A100
--	--------------------------------

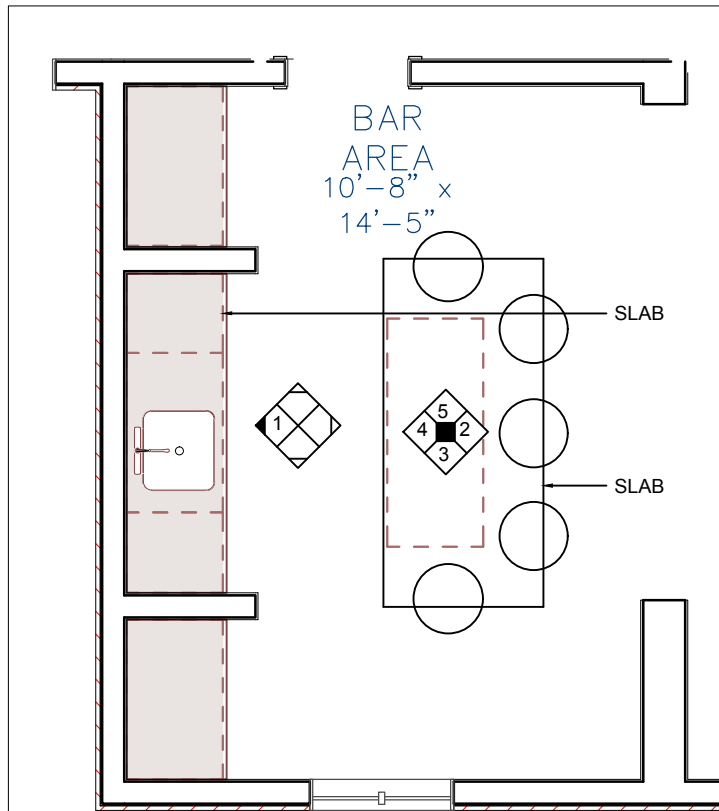

FLOOR PLAN

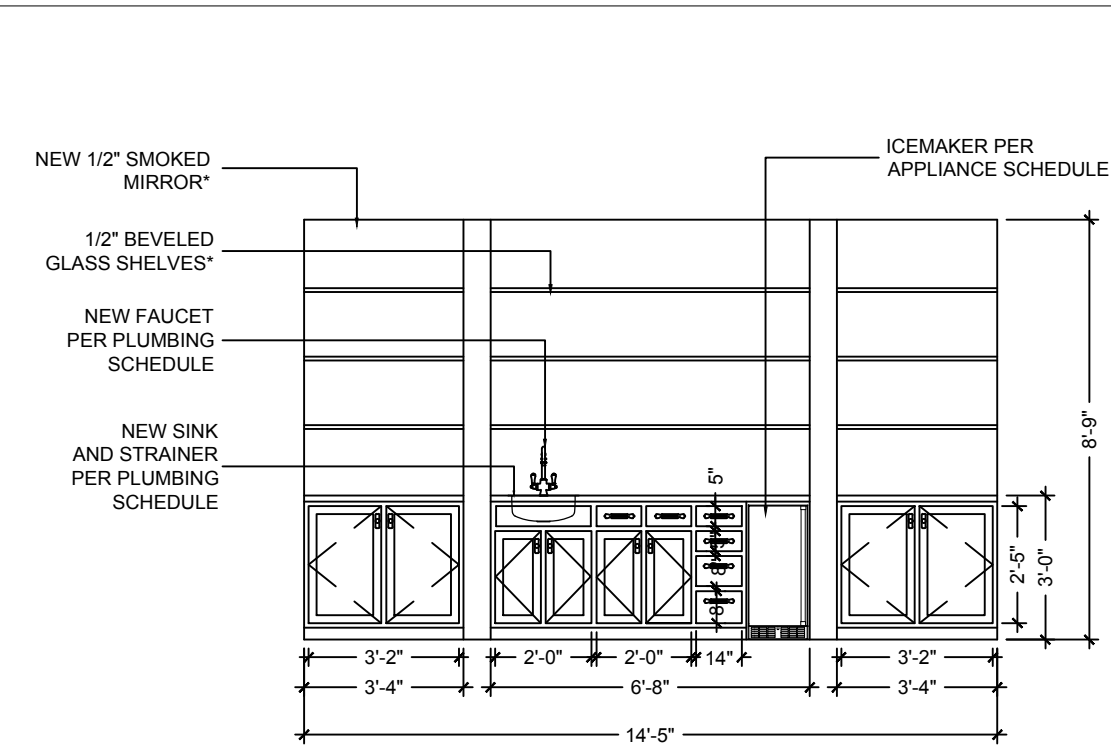

ELEVATION 1

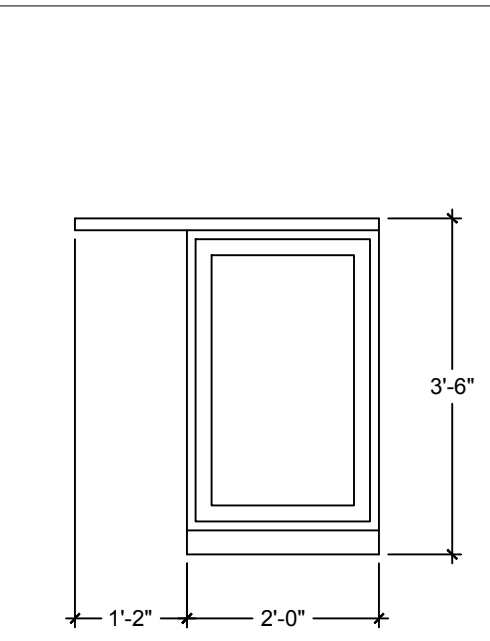

ELEVATION 5
SCALE: 1/2" = 1'-0"

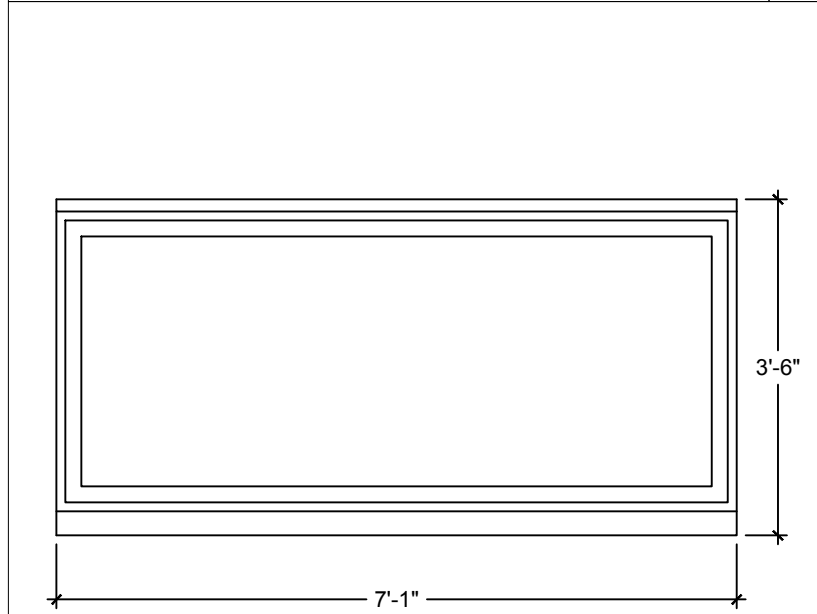

ELEVATION 2

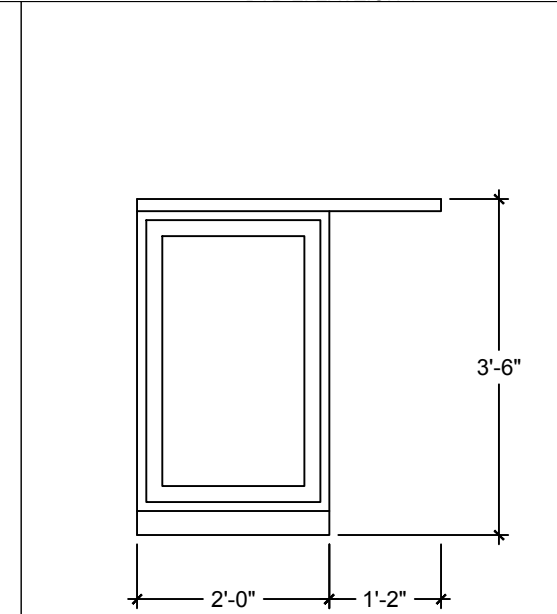

ELEVATION 3

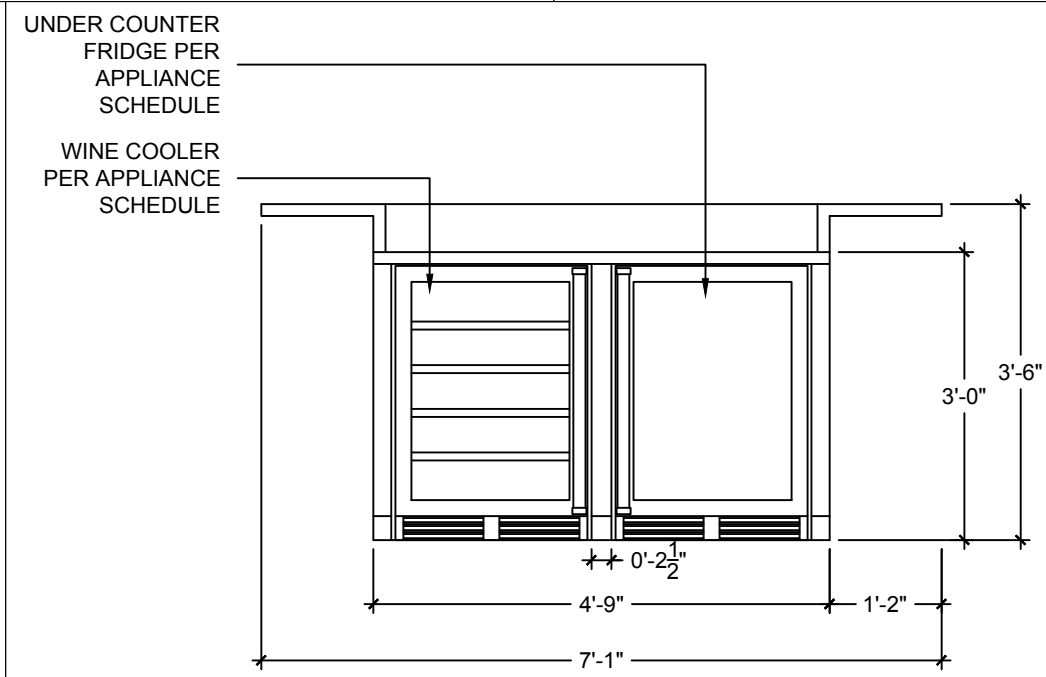

ELEVATION 4

****NOTE:**
CABINETRY TO BE RECLAIMED DOUGLAS FIR
WITH ESPRESSO FINISH
COUNTERS TO BE SLAB
EXPOSED DECORATIVE HINGES
* SHOW SAMPLES TO OWNER

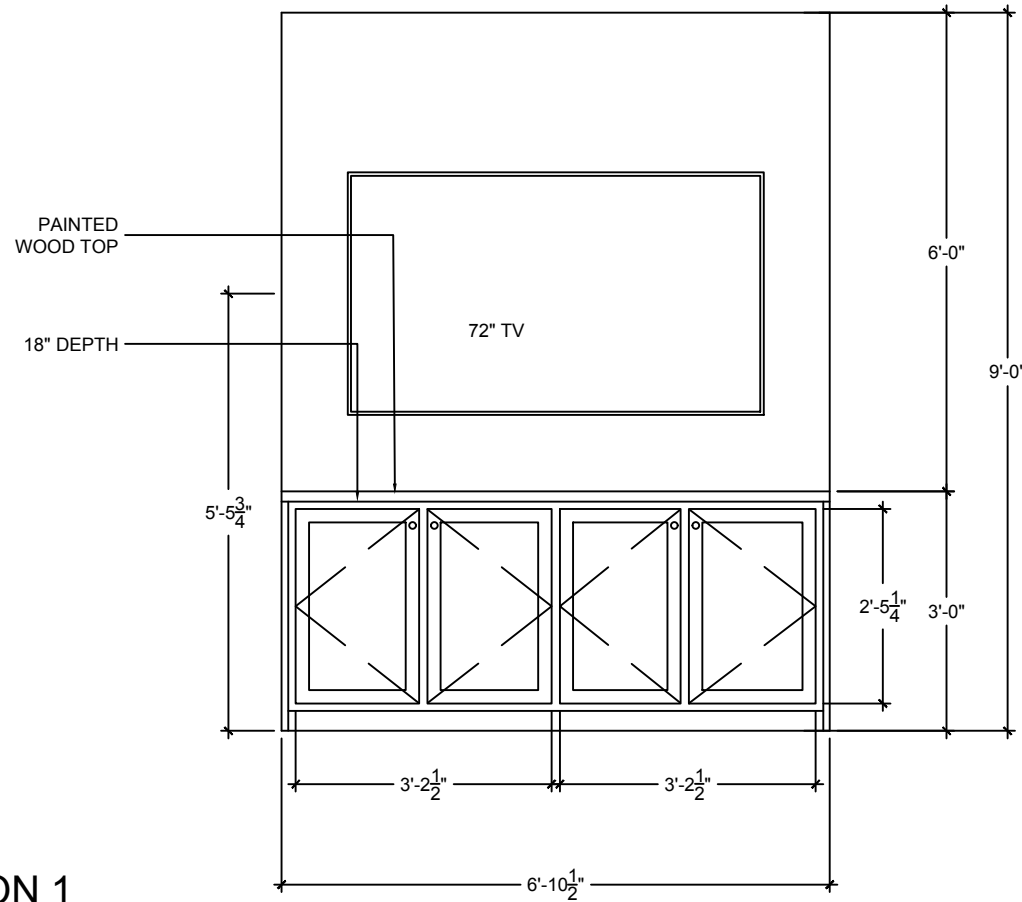
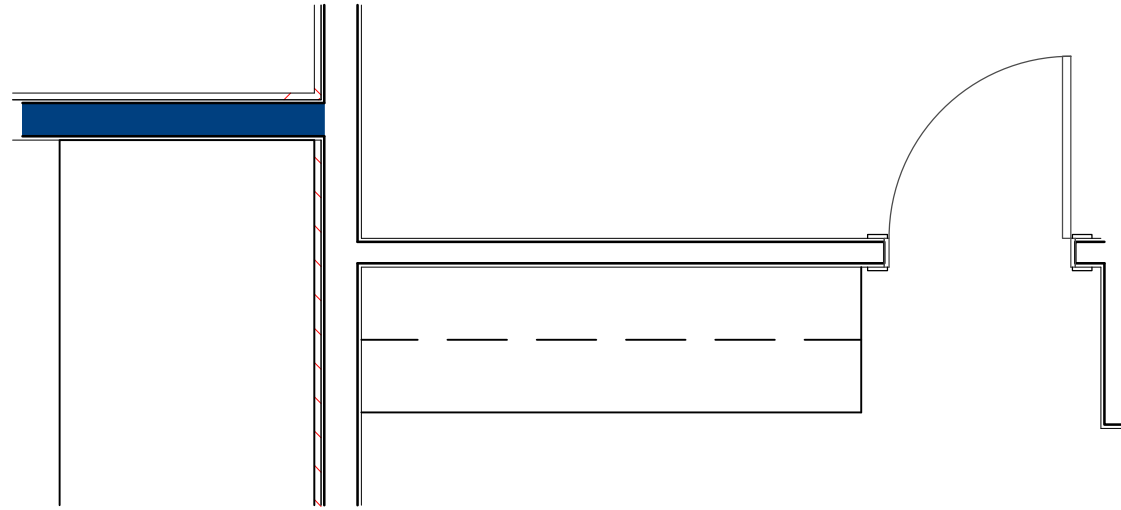

ELEVATION 1

FNAME

REVDATE

USER



PixelArch Ltd.

Canada main office:
3313 Plateau Blvd.
Coquitlam BC V3E 3B8
+1 604 243 3666

US Office:
1442 N. Dale Ave.
Anaheim, CA 92801
+1 310 734 8517

Toll free: 1 844 729 0009
Email: info@pixelarchpro.com

GENERAL NOTE

All measurements to be verified on site by contractor.

REVISED:
January 10, 2017

DATE:
06.03.2016

COPYRIGHT

THIS DRAWING IS AN INSTRUMENT OF SERVICE AND AS SUCH, REMAINS THE PROPERTY OF PIXELARCH LTD. PERMISSION FOR USE OR REPRODUCTION IS LIMITED AND CAN BE EXTENDED ONLY BY WRITTEN PERMISSION WITH OWNER, PIXELARCH LTD.

No.	Revision/Issue	Date

Firm Name and Address

Darren Asad Architect
darrenasad@mail.com

Project Name and Address

901 N BEDFORD DR, BEVERLY HILLS, CA

DRAWING: GREAT ROOM	Sheet
Date: January 10, 2017	oOfO
Scale: 1/2" = 1' - 00"	A100

**** NOTE:**
CABINETRY TO BE PAINT WHITE FINISH

EXPOSED DECORATIVE HINGES

AD 1/2" BEVELED GLASS TOP TO TOP OF CABINET

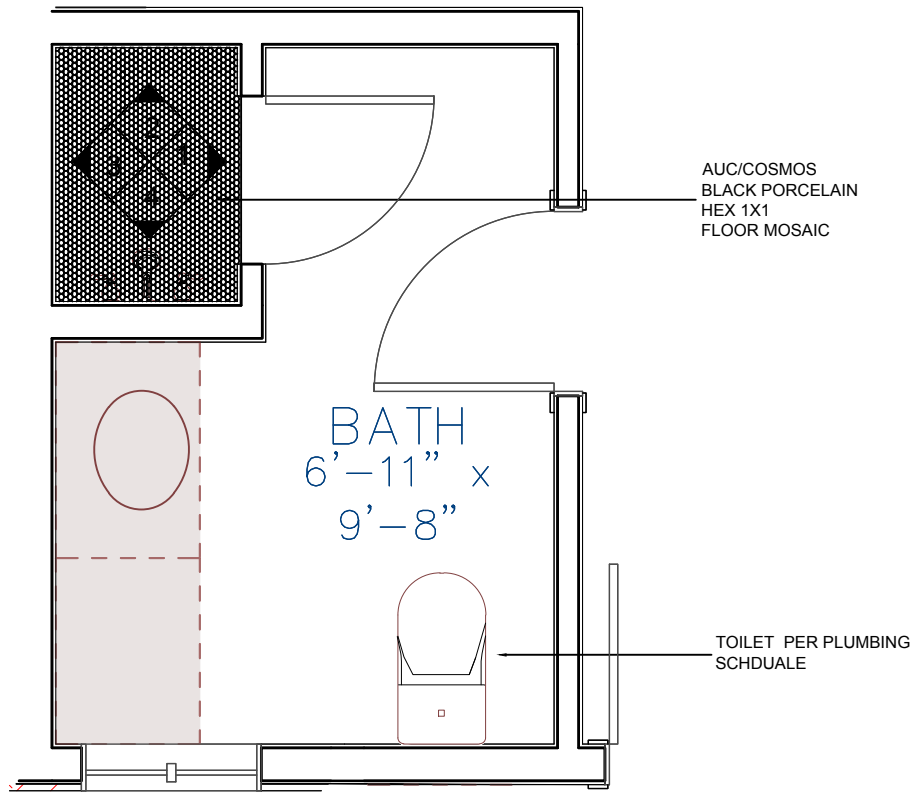

ELEVATION 1
SCALE: 3/8" = 1'-0"

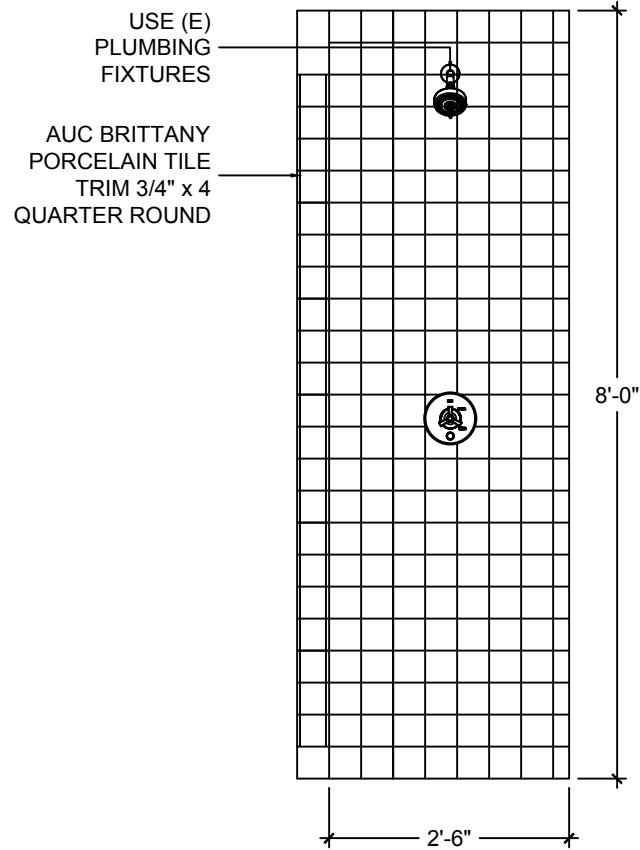

ELEVATION 4

****NOTE**
INSTALL EXISTING
PLUMBING PER
EXISTING FIXTURE
LOCATIONS



PixelArch Ltd.

Canada main office:
3313 Plateau Blvd.
Coquitlam BC V3E 3B8
+1 604 243 3666

US Office:
1442 N. Dale Ave.
Anaheim, CA 92801
+1 310 734 8517

Toll free: 1 844 729 0009
Email: info@pixelarchpro.com

GENERAL NOTE

All measurements to be verified on site by contractor.

REVISED:
January 10, 2017

DATE:
07.06.2016

COPYRIGHT

THIS DRAWING IS AN INSTRUMENT OF SERVICE AND AS SUCH, REMAINS THE PROPERTY OF PIXELARCH LTD. PERMISSION FOR USE OR REPRODUCTION IS LIMITED AND CAN BE EXTENDED ONLY BY WRITTEN PERMISSION WITH OWNER, PIXELARCH LTD.

No.	Revision/Issue	Date

Firm Name and Address

Darren Asad Architect
darrenasad@mail.com

Project Name and Address

901 N BEDFORD DR. BEVERLY HILLS, CA

DRAWING: LIBRARY TILE ELEVATION	Sheet o OF o
Date January 10, 2017	A100
Scale AS NOTED	

FNAME

REVDATE

USER

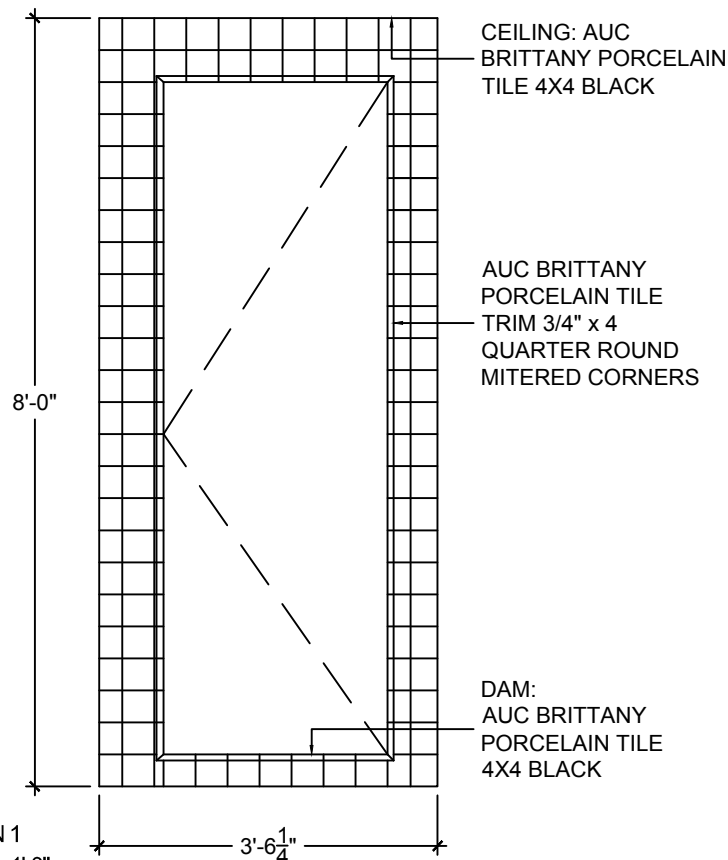

ELEVATION 1
SCALE: 1/2" = 1'-0"

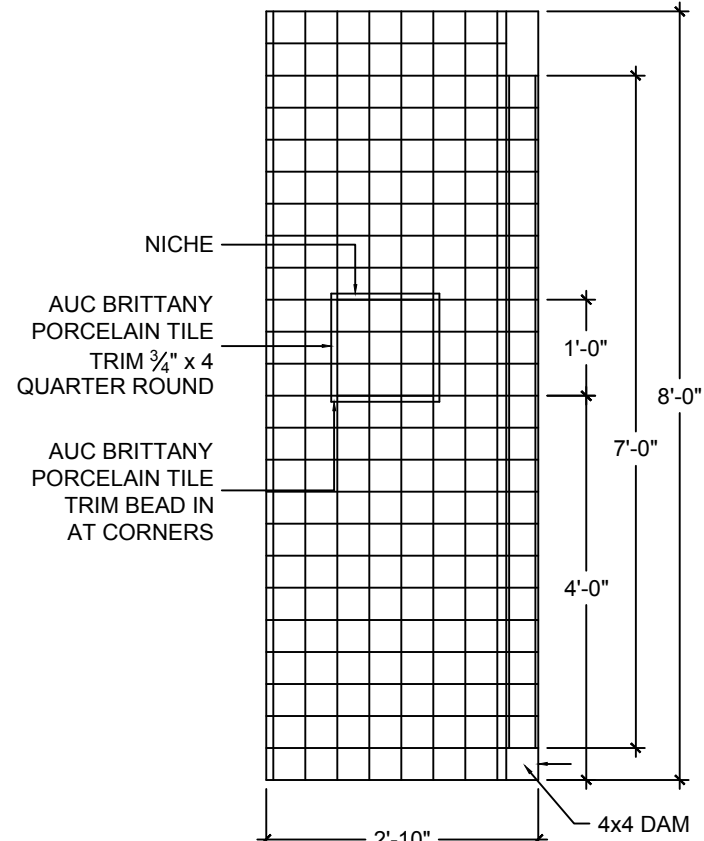

ELEVATION 2

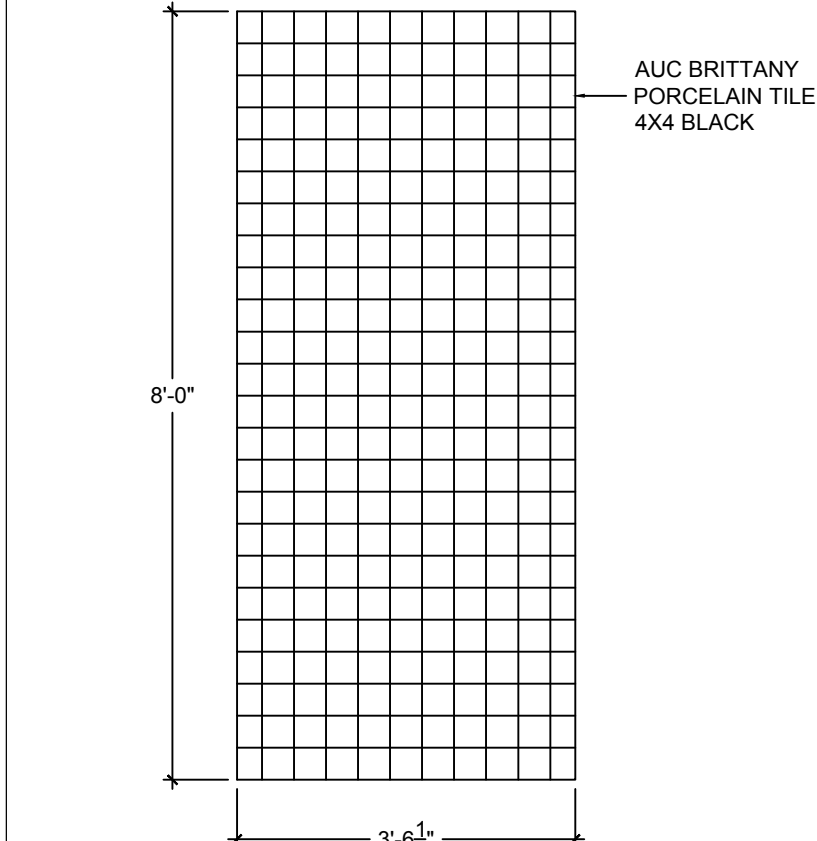

ELEVATION 3



PixelArch Ltd.

Canada main office:
3313 Plateau Blvd.
Coquitlam BC V3E 3B8
+1 604 243 3666

US Office:
1442 N. Dale Ave.
Anaheim, CA 92801
+1 310 734 8517

Toll free: 1 844 729 0009
Email: info@pixelarchpro.com

GENERAL NOTE

All measurements to be verified on site by contractor.

REVISED:
January 10, 2017

DATE:
05.03.2016

COPYRIGHT

THIS DRAWING IS AN INSTRUMENT OF SERVICE AND AS SUCH, REMAINS THE PROPERTY OF PIXELARCH LTD. PERMISSION FOR USE OR REPRODUCTION IS LIMITED AND CAN BE EXTENDED ONLY BY WRITTEN PERMISSION WITH OWNER, PIXELARCH LTD.

No.	Revision/Issue	Date

Firm Name and Address

Darren Asad Architect
darrenasad@mail.com

Project Name and Address

901 N BEDFORD DR. BEVERLY HILLS, CA

DRAWING: POWDER	Sheet 0 OF 0
Date January 10, 2017	A100
Scale 1/2" = 1' - 00"	

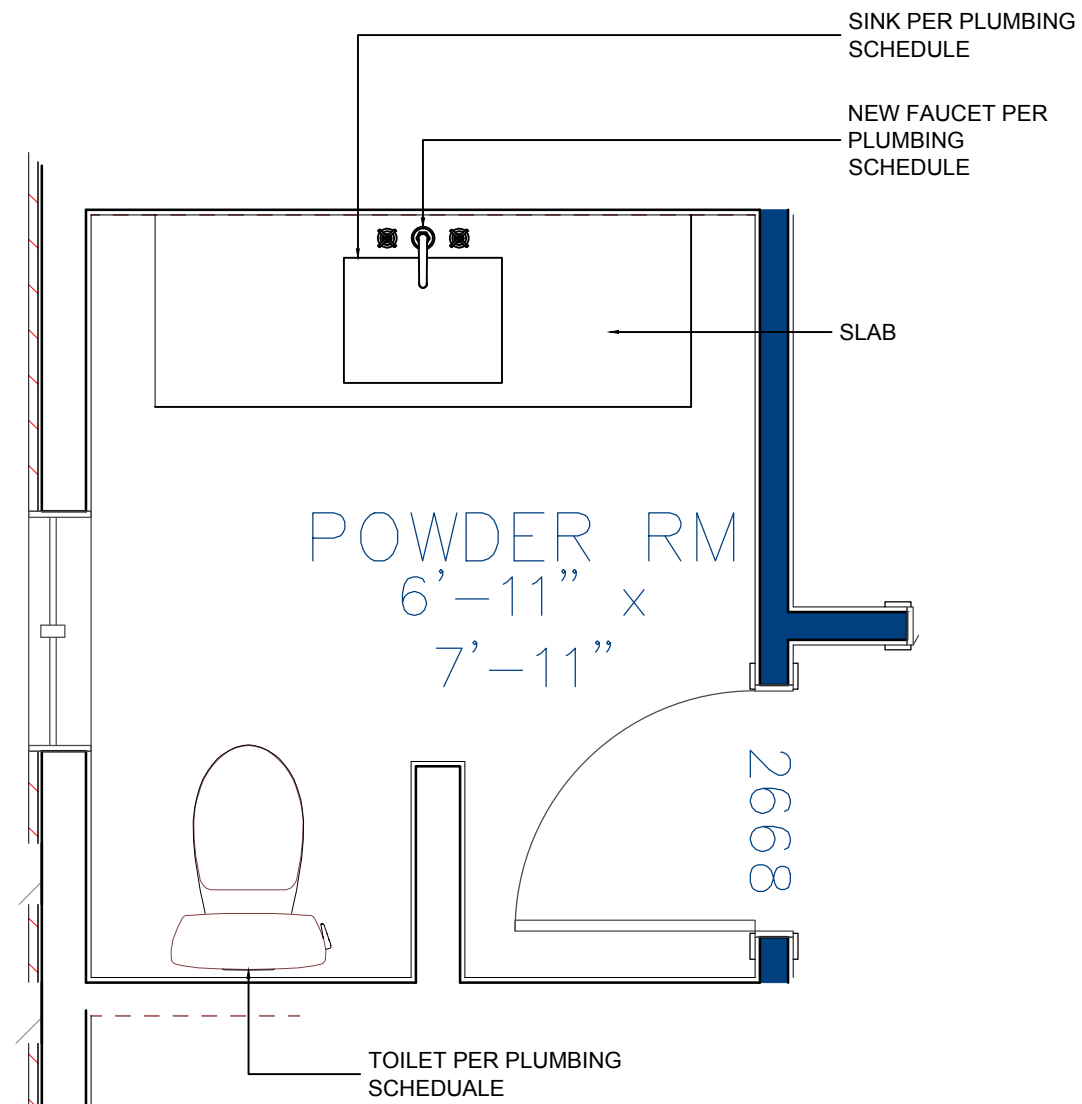

FLOOR PLAN

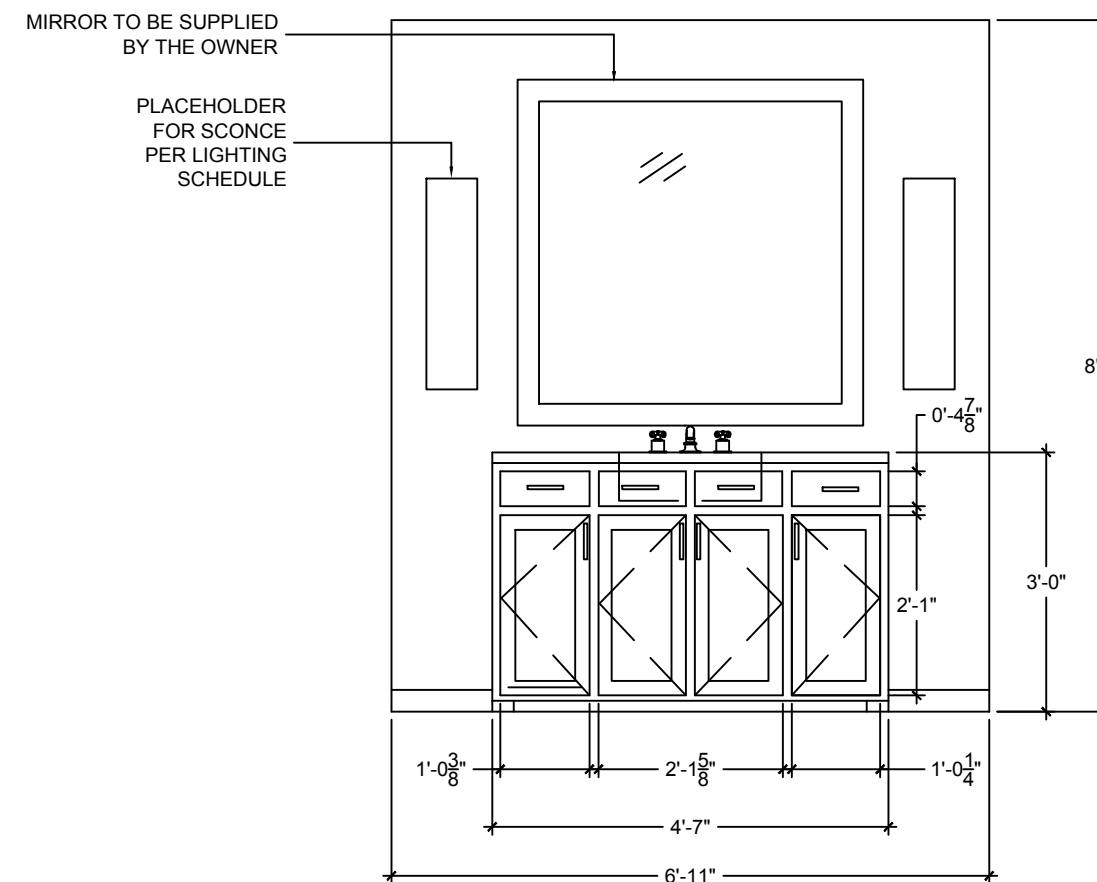

ELEVATION 1

****NOTE:**
CABINERY TO BE RECLAIMED DOUGLAS FIR WITH ESPRESSO FINISH

COUNTER TO BE SLAB

EXPOSED DECORATIVE HINGES

FNAME
REVDATE
USER